

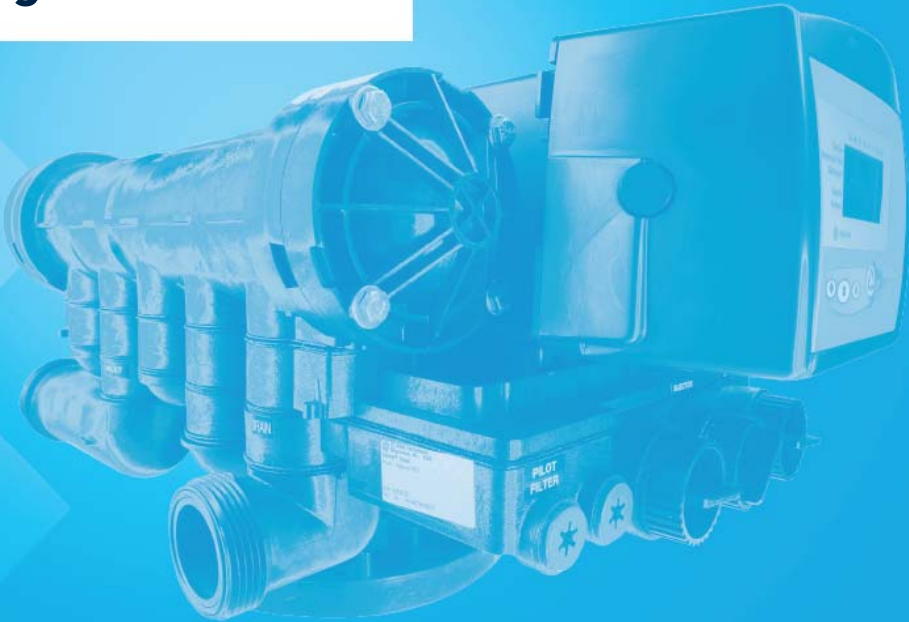

AUTOTROL Magnum 742-762



INSTALLER MANUAL

Table of content

1.	Generalities	6
1.1.	Scope of the documentation	6
1.2.	Release management	6
1.3.	Manufacturer identifier, product	6
1.4.	Abbreviations used	7
1.5.	Norms	7
1.5.1.	Applicable norms	7
1.5.2.	Available certificates	7
1.6.	Procedure for technical support	8
1.7.	Copyright	8
1.8.	Limitation of liability	8
2.	Safety	9
2.1.	Safety pictograms definition	9
2.2.	Safety tags location	9
2.3.	Hazards	9
2.3.1.	Personnel	10
2.3.2.	Material	10
2.4.	Hygiene and sanitization	10
2.4.1.	Sanitary issues	10
2.4.2.	Hygiene measures	10
3.	Description	11
3.1.	Introduction to the Magnum Cv and Magnum IT valves series ...	11
3.2.	Technical specifications	12
3.2.1.	Performance flow rate characteristics	13
3.3.	Outline drawing	14
3.4.	Description and components location	15
3.5.	Options available on the valve	16
3.5.1.	6" flange plastic tank adapter	16
3.5.2.	Refill first	17
3.5.3.	External pilot feed adapter	17
3.5.4.	Magnum switch kit	18
3.5.5.	Hydraulic output signal	23
3.6.	Systems regeneration cycle	24
3.6.1.	298 Valves (5 - Cycle softener)	24
3.6.2.	293 Valves (3 - Cycle filter)	26

4.	System sizing	27
4.1.	Recommendations	27
4.1.1.	Injector and Refill controller charts	27
4.1.2.	Drain line flow control	27
4.1.3.	Recommended backwash flow rates for various media	29
4.2.	Cycle time calculation	29
4.3.	Injector flow rates (tables)	30
4.4.	Standard efficiency exchange capacity	32
5.	Installation	33
5.1.	Safety notices for installation	33
5.2.	Installation environment	33
5.2.1.	General	33
5.2.2.	Electrical	33
5.2.3.	Mechanical	34
5.2.4.	Outdoor Locations	34
5.3.	Integration constraints	35
5.4.	Block diagram and configuration example	35
5.5.	Valve connection to piping	37
5.5.1.	Top-mounted valve installation	37
5.5.2.	Side-mounted valve installation	39
5.6.	Connections (electrical)	40
5.7.	Bypassing	40
5.8.	Drain line connection	41
5.9.	Overflow line connection	42
6.	Programming	43
6.1.	Display	43
6.2.	Commands	45
6.3.	Basic programming	46
6.3.1.	Basic programming 742 - 762 / 298 valve type	46
6.3.2.	Basic programming 742F - 762F / 293 valve type	49
6.4.	Advanced programming	51
6.4.1.	Basic programming parameters (5 - Cycle softener system)	51
6.4.2.	Advanced programming parameters (5 - Cycle softener system)	52
6.4.3.	Basic programming parameters (3 - Cycle filter system)	53
6.4.4.	Advanced programming parameters (3 - Cycle filter system)	54
6.4.5.	Cycle time programming	55
6.4.6.	Diagnostic	56
6.4.7.	Resetting the controller	57

7.	Commissioning	58
7.1.	Water filling, draining and waterproofness inspection	58
7.1.1.	Activating the softener	58
7.1.2.	Additional tips	60
7.2.	Sanitization	60
7.2.1.	Disinfection of water softeners	60
7.2.2.	Sodium or calcium hypochlorite	61
7.2.3.	Electro chlorination	61
8.	Operation	62
8.1.	Recommendations	62
8.2.	Manual regeneration	62
8.3.	To advance regeneration cycles	63
8.4.	To cancel a regeneration	63
9.	Maintenance	64
9.1.	Recommendations	64
9.1.1.	Use original spare parts	64
9.1.2.	Use original approved lubricants	64
9.1.3.	Maintenance instructions	64
9.2.	Cleaning and maintenance	64
9.2.1.	Cleaning and maintenance	64
9.2.2.	Cleaning the injector valve	65
9.2.3.	Cleaning the refill controller	65
9.2.4.	Cleaning the pilot filter screen	66
9.2.5.	Disassembling controller cover	67
9.2.6.	Disassembling camshaft cover	67
9.2.7.	Motor replacement	68
9.2.8.	Camshaft replacement	69
9.2.9.	Optical sensor and controller replacement	70
9.2.10.	Turbine cleaning or replacement	71
9.2.11.	Top plate and disc valve replacement	72
9.2.12.	Cartridge replacement	73
10.	Troubleshooting	74
10.1.	Logix controller	74
10.2.	Magnum IT and Cv valve	75
10.3.	Magnum valve cartridge	77

11.	Spare parts	79
11.1.	Magnum Logix valve body	79
11.2.	Magnum connections	80
11.3.	Magnum Logix camshaft and pilot	81
11.4.	Magnum refill controller assembly	82
11.5.	Magnum injector assembly	83
11.6.	Magnum drain line flow controls assembly	84
11.7.	Magnum cartridges	86
11.8.	Magnum Logix controllers	87
11.9.	Magnum IT turbine	88
11.10.	2" external turbine assembly	89
11.11.	1" external turbine assembly	89
11.12.	Magnum miscellaneous	90
11.13.	Magnum 298 installation components	91
11.14.	Magnum 293 installation components	92
12.	Scrapping	93

1. Generalities

1.1. Scope of the documentation

The documentation provides the necessary information for appropriate use of the product. It informs the user to ensure efficient execution of the installation, operation or maintenance procedures.

The content of this document is based on the information available at the time of publication. The original version of the document was written in English.

For safety and environmental protection reasons, the safety instructions given in this documentation must be strictly followed.

This manual is a reference and will not include every system installation situation. The person installing this equipment should have:

- Training in the 700 Logix series controllers and water softener installation;
- Knowledge of water conditioning and how to determine proper controller settings;
- Basic plumbing skills.

This document is available in other languages on <https://www.pentairaquaeurope.com/product-finder/product-type/control-valves>

1.2. Release management

Revision	Date	Author	Description
A	02.08.2017	STF	First edition

1.3. Manufacturer identifier, product

Manufacturer: Pentair Manufacturing Italy Srl
 Via Masaccio, 13
 56010 Lugnano di Vicopisano (PI) – Italy

Product: Magnum 742-762

1.4. Abbreviations used

DF	Down Flow
UF	Up Flow
Inj	Injector
DLFC	Drain Line Flow Controller
BLFC / Refill Flow Controller	Brine Line Flow Controller
QC	Quick Connect
Regen	Regeneration
SBV	Safety Brine Valve
TC	Time Clock

1.5. Norms

1.5.1. Applicable norms

Comply with the following guidelines:

- DM174: "Regulation of materials and objects that can be used in stationary collection, treatment, supply and distribution of water intended for human consumption"
- Attestation de Conformité Sanitaire (ACS): "Test and Certification valid for France performed by independent laboratories for the evaluation of materials and components that are in contact with drinking water."
- 2006/42/EC: Machinery Directive
- 2014/35/UE: Low Voltage Directive;
- 2014/30/UE: Electromagnetic compatibility;
- 2011/65/EC: Restriction of use of certain hazardous substances in electrical and electronic equipment (RoHS);

Meets the following technical standards:

- IEC/EN 60335-1
- IEC 61010-1
- EN 55014-1
- EN 55014-2
- EN 61000-3-2: 2006 + A1: 2009 + A2: 2009
- EN 61000-3-3: 2008
- EN 61000-6-2: 2005
- EN 61000-6-3: 2007 + A1: 2011
- EN 61326-1

1.5.2. Available certificates

- CE
- DM174
- ACS

Access to all certifications:



1.6. Procedure for technical support

Procedure to follow for any technical support request:

- A** Collect the required information for a technical assistance request.
 - Product identification [see 2.2. Safety tags location, page 9 and 9.1. Recommendations, page 64];
 - Problem description of the device.
- B** Please refer to the "Troubleshooting" chapter, page 74. If the problem persists contact your supplier.

1.7. Copyright

© 2017 Pentair International Sàrl All rights reserved.

1.8. Limitation of liability

Pentair Quality System EMEA products benefit, under specific conditions, from a manufacturer warranty that may be invoked by Pentair's direct customers. Users should contact the vendor of this product for applicable conditions and in case of a potential warranty claim.

Any warranty provided by Pentair regarding the product will become invalid in case of:

- Improper installation, improper programming, improper use, improper operation and/or maintenance leading to any kind of product damages;
- Improper or unauthorized intervention on the controller or components;
- Incorrect, improper or wrong connection/assembly of systems or products with this product and vice versa;
- Use of a non-compatible lubricant, grease or chemicals of any type and not listed by the manufacturer as compatible for the product;
- Failure due to wrong configuration and/or sizing.

Pentair accepts no liability for equipment installed by the user upstream or downstream of Pentair products, as well as for process/production processes which are installed and connected around or even related to the installation. Disturbances, failures, direct or indirect damages that are caused by such equipment or processes are also excluded from the warranty. Pentair shall not accept any liability for any loss or damage of profits, revenues, use, production, or contracts, or for any indirect, special or consequential loss or damage whatsoever. Please refer to the Pentair List Price to know more about terms and conditions applicable to this product.

2. Safety

2.1. Safety pictograms definition



Caution

Warns of a risk of minor injury or major material damage to the device or environment.



Warning

Warns against serious personal injury and damage to health.



Danger

Warns against serious personal injury or death.



Mandatory

Standard or measure to apply.



Note

Comment



Prohibition

Restriction to be observed.

2.2. Safety tags location

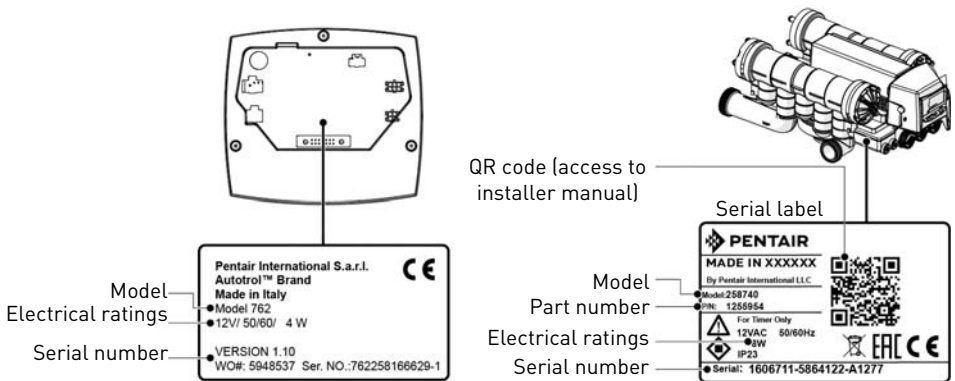

Note

Ensure that the safety tags on the device are completely legible and clean. If necessary, replace them with new tags and put them in the same places.

2.3. Hazards

All the safety and protection instructions contained in this document must be observed in order to avoid temporary or permanent injury, damage to property or environmental pollution.

At the same time, any other legal regulations, accident prevention and environmental protection measures, as well as any recognized technical regulations relating to appropriate and risk-free methods of working which apply in the country and place of use of the device must be adhered to.

Any non-observation of the safety and protection rules, as well as any existing legal and technical regulations, will result in a risk of temporary or permanent injury, damage to property or environmental pollution.

2.3.1. Personnel

Only qualified and professional personnel, based on their training, experience and instruction as well as their knowledge of the regulations, the safety rules and operations performed, are authorized to carry out necessary work.

2.3.2. Material

The following points must be observed to ensure proper operation of the system and the safety of user:

- Be careful of high voltages present on the transformer (230V).
- Do not put your fingers in the system (risk of injuries with moving parts and shock due to electric voltage).

2.4. Hygiene and sanitization

2.4.1. Sanitary issues

Preliminary checks and storage

- Check the integrity of the packaging. Check that there is no damage and no signs of contact with liquid to make sure that no external contamination occurred.
- The packaging has a protective function and must be removed just before installation. For transportation and storage appropriate measures should be adopted to prevent the contamination of materials or objects themselves.

Assembly

- Assemble only with components which are in accordance with drinking water standards.
- After installation and before use, perform one or more manual regenerations in order to clean the media bed. During such operations, do not use the water for human consumption. Perform a disinfection of the system in the case of installations for treatment of drinking water for human use.



Note

This operation must be repeated in the case of ordinary and extraordinary maintenance. It should also be repeated whenever the system remains idle for a significant time.



Note

Valid only for Italy: In case of equipment used in accordance with the DM25, apply all the signs and obligations arising from the DM25.

2.4.2. Hygiene measures

Disinfection

- The materials used for the construction of our products meet the standards for use with potable water; the manufacturing processes are also geared to preserving these criteria. However, the process of production, distribution, assembly and installation, may create conditions of bacterial proliferation, which may lead to odor problems and water contamination.
- It is therefore strongly recommended to sanitize the products. See 7.2. Sanitization, page 60.
- Maximum cleanliness is recommended during the assembly and installation.
- For disinfection, use Sodium or Calcium Hypochlorite and perform a manual regeneration.

3. Description

3.1. Introduction to the Magnum Cv and Magnum IT valves series

The Magnum valve is available in several configurations :

	Magnum Cv	Magnum IT
Turbine	External turbine	Internal turbine
Inlet diameter	3.91 cm (1 1/2")	5.08 cm (2")
Outlet diameter	3.91 cm (1 1/2")	5.08 cm (2")
Drain diameter	3.91 cm (1 1/2")	3.91 cm (1 1/2")

Logix Magnum Time Clock 742 / 298 Logix Magnum Demand 762 / 298	Logix Magnum Time Clock 742F / 293 Logix Magnum Demand 762F / 293
5 - Cycle softener	3 - Cycle filter
C0: Service C1: Backwash C2: Brine draw C3: Slow rinse C5: Fast rinse C8: Refill	C0: Service C1: Backwash C5: Fast rinse



Note

Both valves configuration (293 & 298) are available with Magnum Cv and Magnum IT series.

Magnum Cv

Magnum IT

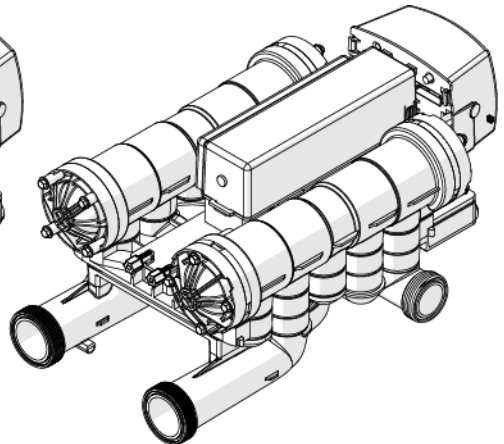
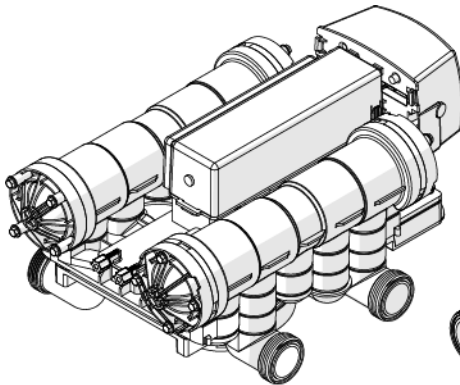

3.2. Technical specifications

Design specifications/ratings

Valve body	Thermoplastic
O-rings	EPDM
Weight (valve with controller)	10.6 kg
Recommended operating pressure	1.72 - 6.9 bar
Water temperature	2 - 38°C
Ambient temperature	2 - 48.9°C

Flow rates (valve only)

Service at 1.03 bar (15 psi) drop	17.3 m ³ /h
Backwash at 1.72 bar (25 psi) drop	20.2 m ³ /h
Service	Kv = 17 m ³ /h (Cv = 19.5 gpm)
Backwash.....	Kv = 19.9 m ³ /h (Cv = 17.8 gpm)

Valve connections

Tank Adapter Thread	4" 8 UN
Inlet/Outlet Threads	2" Connections NPT or BSPT, Female, CPVC
Drain line*	1 1/2" Connections for NPT or BSPT, Female, CPVC
Brine line	3/4" NPT
Riser tube [Ø]	1 1/2"
Riser installation	Above top of tank 15.9 mm ± 3 mm (5/8" ± 1/8")
Pilot drain and auxiliary hydraulic output	6.4 mm (1/4") tube fitting

* Valve installed drain flow controls available (1.14 - 9.08 m³/h). If higher backwash flow is needed, an external flow control will be required.

Electrical

Controller Operating Voltage	12 VAC (requires use of Pentair Water supplied transformer)
Input Supply Frequency.....	50 or 60 Hz
Motor Input Voltage	12 VAC
Controller Power Consumption	3 W average
Protection rating.....	IP23

3.2.1. Performance flow rate characteristics

The graph shows the pressure drop created by the valve itself at different flow rates. It makes it possible to predetermine the maximum flow rate going through the valve depending on the system settings (inlet pressure etc). It also makes it possible to determine the valve pressure drop at a given flow rate, and therefore to evaluate the system pressure drop vs flow rate.

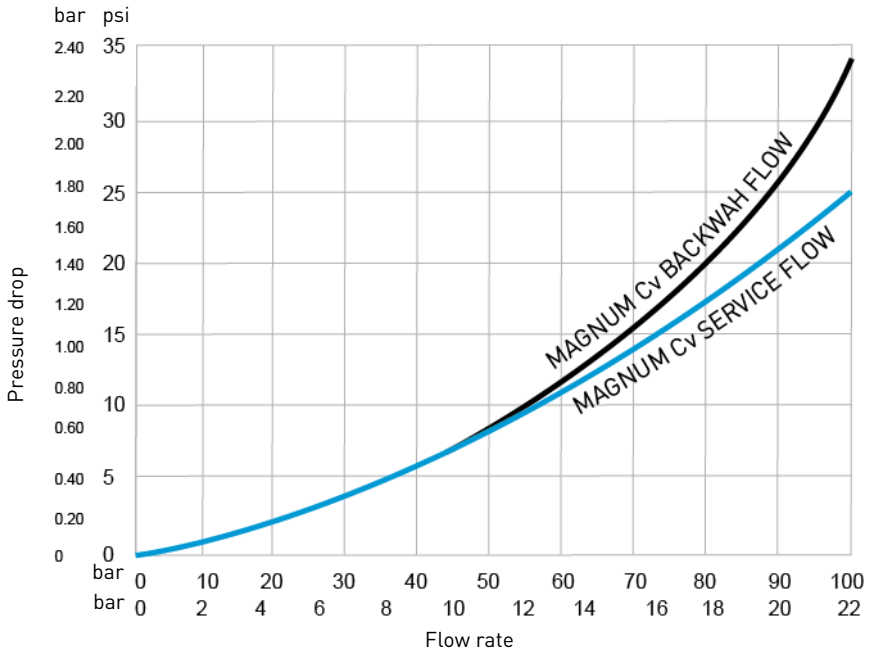

3.3. Outline drawing

Magnum CV

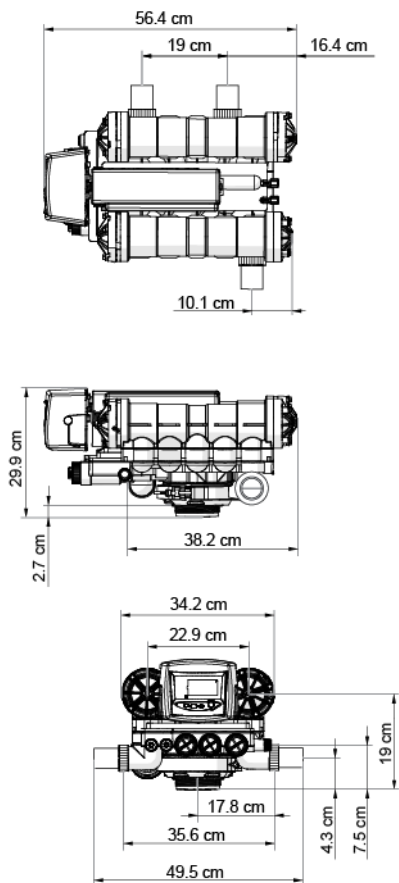

Magnum IT

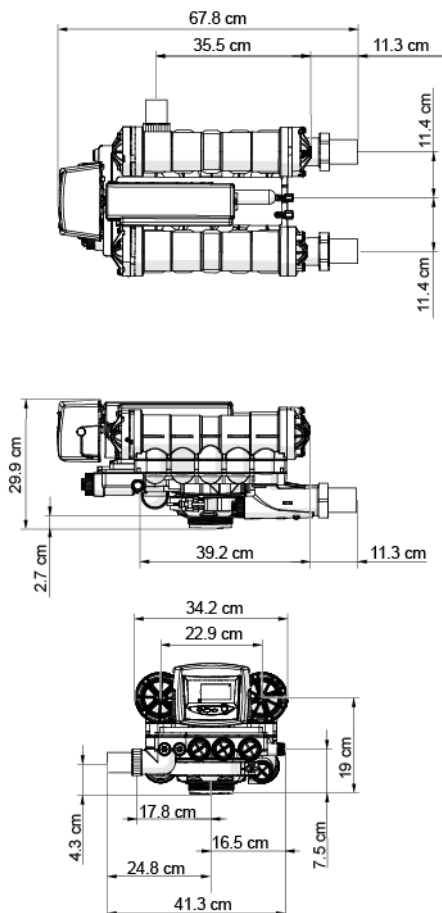

3.4. Description and components location

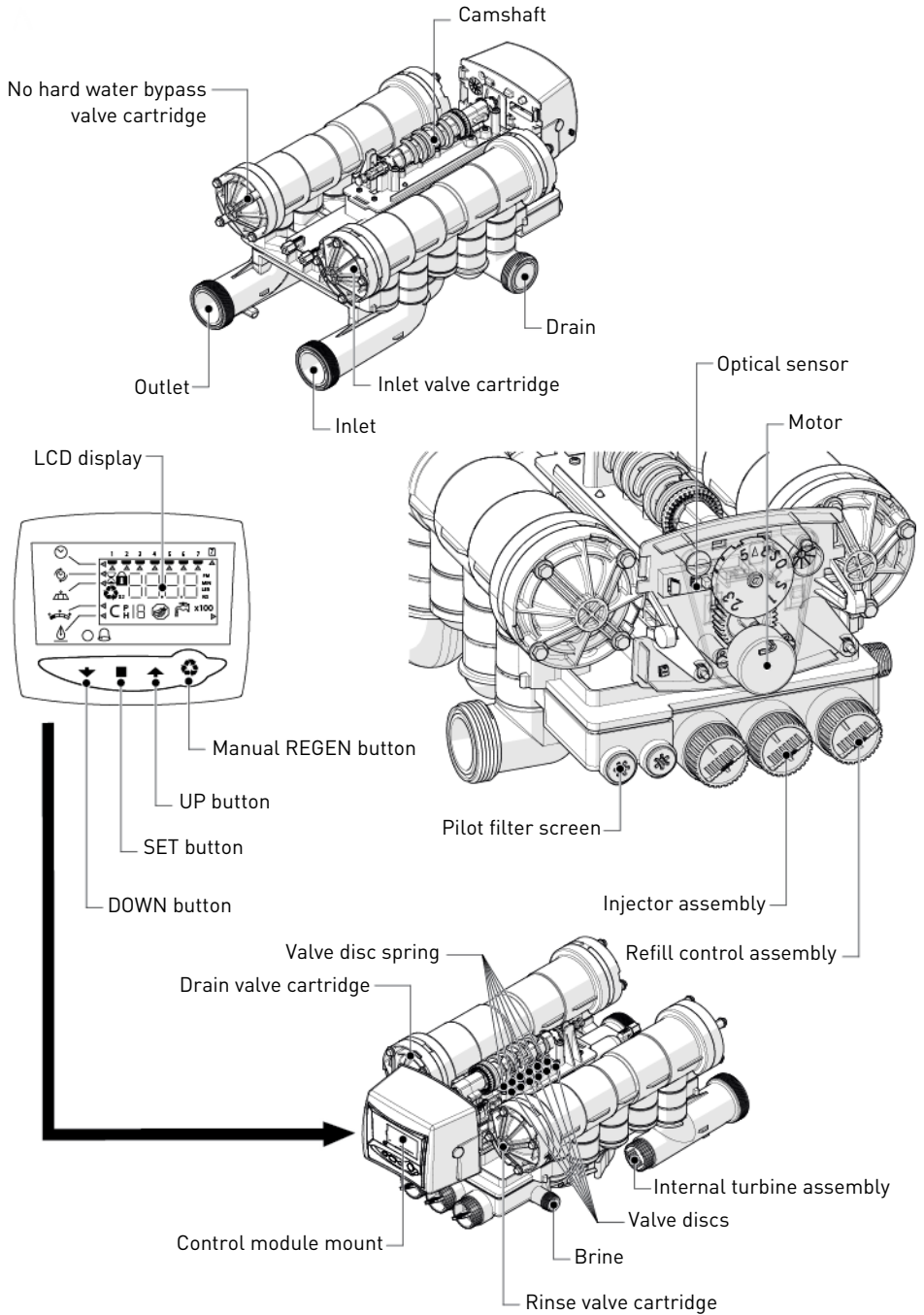

3.5. Options available on the valve

3.5.1. 6" flange plastic tank adapter

This adapter allows a direct connection from the 6" flanged tank to the Magnum valve. It is manufactured from the same glass-filled thermoplastic as the Magnum valve body.

When incorporating this adapter into your system, no metal components are in contact with the water flowing through which enables the Magnum Control Valve's use in corrosive applications.

Like the stainless steel threaded tank adapter, the 6" flange adapter allows the valve to rotate 360-degrees in relation to the tank. This adapter eliminates the need for an additional flange-to-thread adapter component in a large tank system.

This adapter is still to be fitted with the stainless steel quick-connect clamp that will simplify installation and maintenance.



Stainless steel tank adapter



Quick-connect clamp



Top view



Bottom view

Plastic tank adapter

3.5.2. Refill first

The logix 742 and 762 controllers allow you to refill the brine tank first when used in softener mode. This feature allows the brine tank to be dry during the complete service cycle, reducing the caking phenomena.

When a regeneration is initiated, the timer places the valve in refill position. Once the refill cycle is done, the timer puts the valve back into service for 2 hours giving a sufficient time to make the brine in the brine tank. After 2 hours the softener will operate a regeneration as usual, just skipping the refill cycle that will be done just before the next regeneration cycle.

3.5.3. External pilot feed adapter

A small check valve is incorporated inside the Magnum pilot system. This removable and replaceable check valve maintains the valve cartridge position in the event of pressure loss.

This check valve is compatible with an external pilot feed adapter and can be used with separate source pilot pressure if desired.

No.	Operation
A	Remove the pilot filter screen assembly (1).
B	Install the external pilot feed adapter (2) or the pilot system check valve (3).

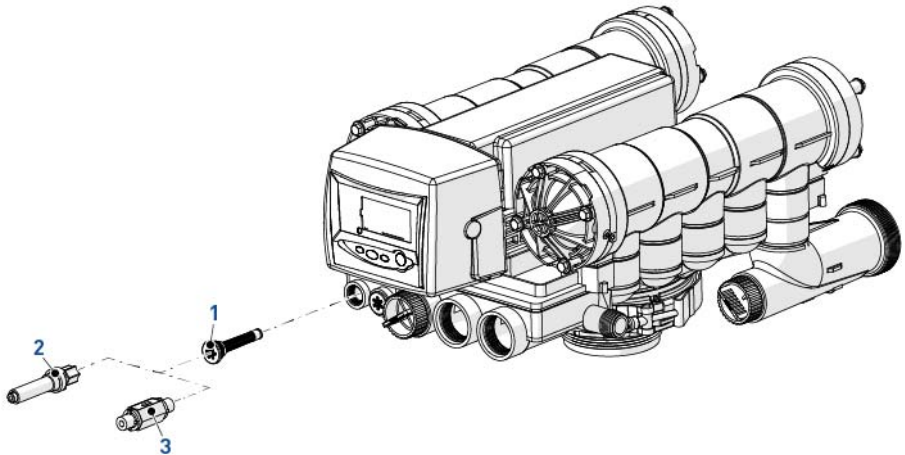

3.5.4. Magnum switch kit

Optional switch kits can be used on the Magnum Cv valve to provide electrical signalling capabilities. Used in conjunction with breakaway cams, the switches will provide a signal to external devices during the various cycles of the valve operations.

3.5.4.1 Switch mounting instructions

No.	Operation
A	Fasten the switch-mounting bracket (4) to the Magnum Cv valve (1) using the thread-forming mounting screw (3) (see picture 1). The shorter, clipped edge of the bracket should be positioned over the guide pin (5) and screw hole located behind the B1/B2 cam (2 / 6).
B	<p>Attach the switches to the bracket using the screws, nuts and washers provided. The screws should be inserted so that the washer and nuts are on the backside of the switch SW1.</p> <p>When mounting a single switch, the switch is mounted to the back of the bracket directly in front of the number one cam (see picture 1).</p> <p>When a triple switch is mounted, one switch is located on the back of the bracket and two are located on the front (see picture 2). For multiple switches it is easiest to slide two switches onto the screws and then insert the screws through the bracket. The final switch is then added to the screws and fastened with the washers and nuts (see picture 2).</p> <p>Switches are mounted with the switch arm adjacent to the breakaway cams and the electrical contacts directed away from the camshaft (see picture 3).</p>
C	<p>Each switch has three terminals (see picture 4), the common terminal is on the side (labelled COM1), and two terminals are on the bottom.</p> <p>The lower terminal which is closest to the camshaft is the closed contact (labelled NC2), the remaining terminal is the open contact (labelled NO3).</p> <p>Connect the cable lead wires to the appropriate terminal using the crimp-on terminal connectors provided. Auxiliary switch cables are available in 3 m (P/N 1041065) and 6 m (P/N 1041066) lengths. The connections for these cables are: black to common terminal, red to normally open terminal and green to normally closed terminal.</p>

Picture 1

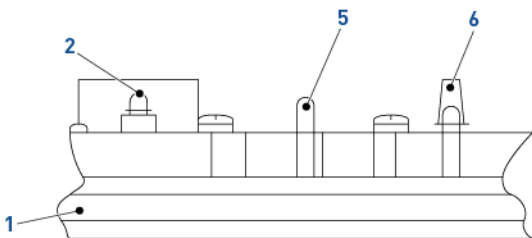
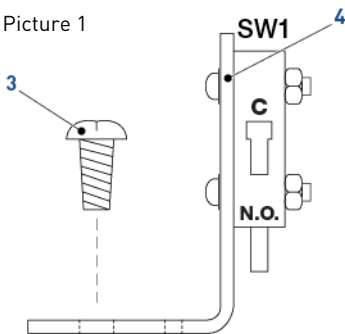

Picture 2

Picture 3

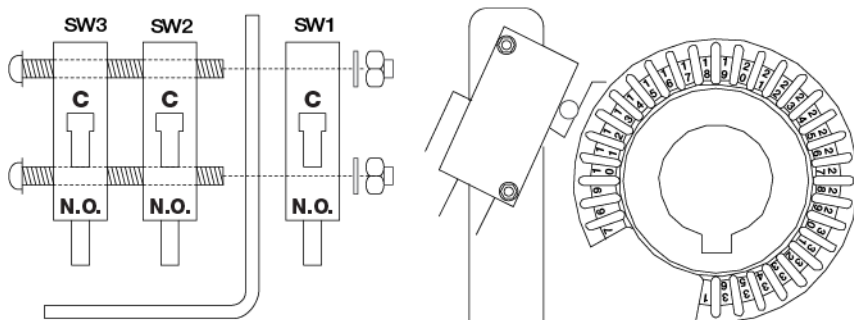

Picture 4

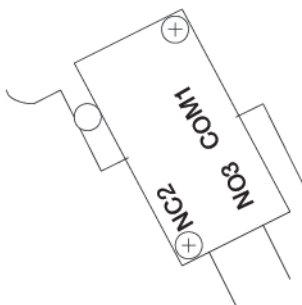

3.5.4.2 Breakaway switch cam description

The breakaway switch cam has been divided into 36 equal sections with each section representing approximately 10-degrees of the cam rotation. Each section is consecutively numbered 1 through 36 to aid in customized cam operating design.

Each cam section, as well as the outside ring of the cam that the switch arm rides on, is molded of a high strength, co-polymer resin. Although a single cam section is strong enough to operate the switch, it is recommended that a minimum of three continuous cam sections always be incorporated into the cam timing design for the on / off operation of the switch. Likewise, it is recommended that a minimum of three cam sections be removed to ensure the proper on / off operation of the switch.



Caution

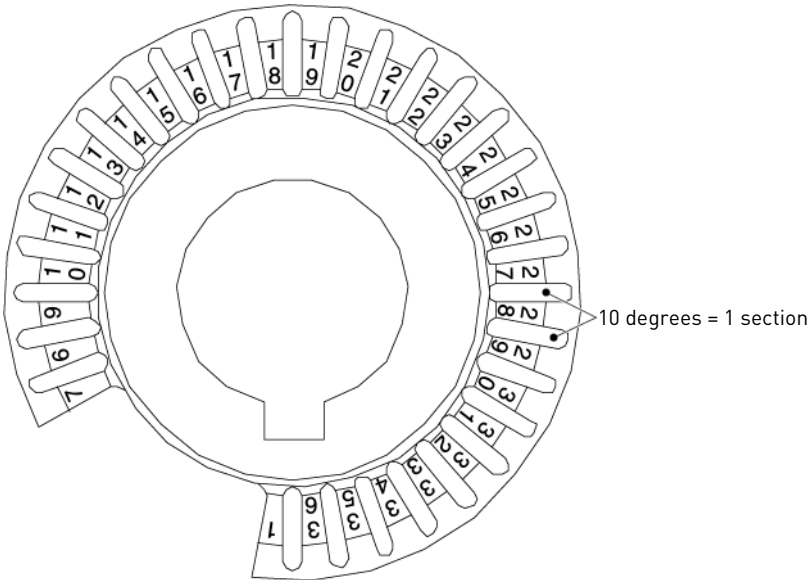

The breakaway switch cam (P/N 1034356) cannot be used as a substitute for any standard Magnum Cv Series pilot cam lobe.



3.5.4.3 Breakaway switch cam instructions

Based on the system requirements and the external devices used, determine the program timing, i.e., when the external devices need to operate, either open or close.

Typical external devices would be solenoids, solenoid operated diaphragm valves, relays, and chemical feed pumps. Using the instructions below, sections can be removed from the breakaway cam to allow signalling during the desired cycles. One cam can be used to signal multiple non-contiguous cycles.

No.	Operation														
A	<p>Determine which breakaway cam sections need to be removed using the chart below. In order to assure that switch deactivation occurs, at least three sections must be removed from the breakaway switch cam.</p> <p>The sections should be removed in a clockwise fashion, starting with the first number and ending with the second (see picture 1). Utilizing the timing chart on the back, determine if the switch arm should be riding on the cam [actuated] or not [relaxed].</p> <table border="1" data-bbox="275 552 893 778" style="margin-left: auto; margin-right: auto;"> <thead> <tr> <th>Cycle</th> <th>Section numbers</th> </tr> </thead> <tbody> <tr> <td>Service (C0)</td> <td>19, 20, 21, 22, 23, 24, 25</td> </tr> <tr> <td>Backwash (C1)</td> <td>26, 27, 28, 29, 30, 31, 32</td> </tr> <tr> <td>Brine (C2)</td> <td>33, 34, 35, 36, 1</td> </tr> <tr> <td>Slow rinse (C3)</td> <td>2, 3, 4, 5, 6, 7, 8, 9, 10</td> </tr> <tr> <td>Fast rinse (C5)</td> <td>11, 12, 13, 14</td> </tr> <tr> <td>Refill (C8)</td> <td>15, 16, 17, 18</td> </tr> </tbody> </table>	Cycle	Section numbers	Service (C0)	19, 20, 21, 22, 23, 24, 25	Backwash (C1)	26, 27, 28, 29, 30, 31, 32	Brine (C2)	33, 34, 35, 36, 1	Slow rinse (C3)	2, 3, 4, 5, 6, 7, 8, 9, 10	Fast rinse (C5)	11, 12, 13, 14	Refill (C8)	15, 16, 17, 18
Cycle	Section numbers														
Service (C0)	19, 20, 21, 22, 23, 24, 25														
Backwash (C1)	26, 27, 28, 29, 30, 31, 32														
Brine (C2)	33, 34, 35, 36, 1														
Slow rinse (C3)	2, 3, 4, 5, 6, 7, 8, 9, 10														
Fast rinse (C5)	11, 12, 13, 14														
Refill (C8)	15, 16, 17, 18														
	<p>Tip</p> <p>Remember that the switch operates either normally open or normally closed depending upon how it is wired.</p>														
B	<p>Using diagonal cutters or a razor knife, cut through the cam on either side of the section you wish to remove. The breakaway cam section should be trimmed to the edge of the section which is to remain on the breakaway cam, see picture 2.</p> <p>Cut the outside ring first, then at the score line on the bottom of each section near the center ring.</p>														
	<p>Tip</p> <p>When starting to remove sections, start two or three sections before the section required. Then remove one section at a time until the required section is reached. This procedure eliminates the potential of damage to usable sections.</p>														
C	<p>When all of the desired sections have been removed, add the breakaway switch cam(s) to the camshaft after the B1/B2 pilot cam.</p> <p>The switch cam can be installed onto the camshaft in only one direction. The numbers on the breakaway switch cam should face the controller.</p>														
D	<p>Replace the standard pilot cams in the proper order and reinstall the camshaft onto the control valve. Refer to 9.2.8. Camshaft replacement, page 69 for instructions on the removal and replacement of the camshaft assembly.</p>														

Example :
Removing sections
36 to 13 in a
clockwise direction
will provide an
electrical signal
during the slow
rinse cycle.

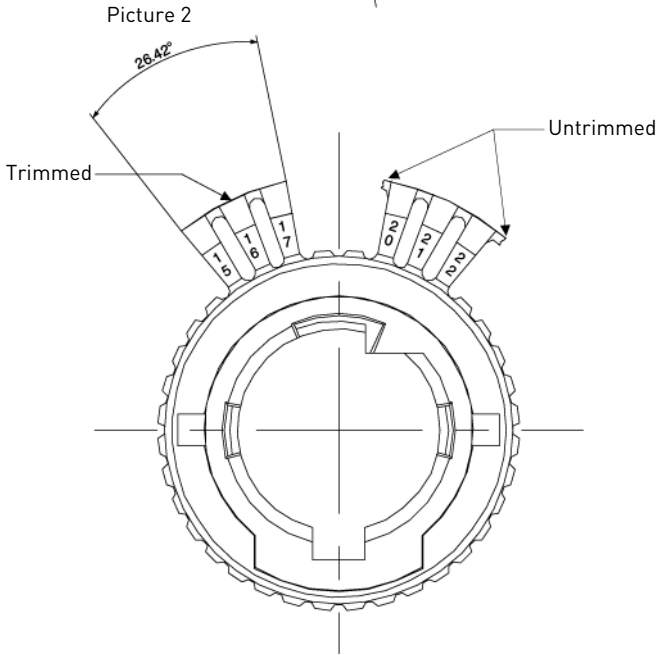
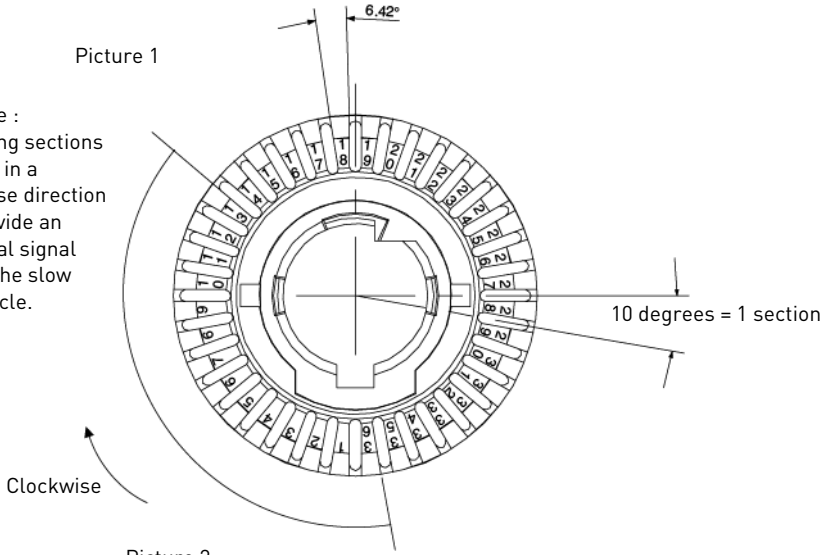

3.5.5. Hydraulic output signal

An optional hydraulic output signal is available on the valve. An optional cam lobe on pilot valve #6 is used on the camshaft assembly to initiate the hydraulic output signal during regeneration or backwash.

The hydraulic line pressure signal is available through the 1/4" connection on the back of the valve (marked "Aux").

Remove the tube cap installed for shipping. Install one of the available cam lobes

P/N 1000554	Provides a hydraulic signal from the beginning of Backwash through the start of Refill cycle.
P/N 1000553	Provides a hydraulic signal from the beginning of Backwash through the end of Refill cycle.
P/N 1041064	Breakaway cam. It can be programmed to send a hydraulic signal at any time during the regeneration or backwash cycle. The camshaft must be turning for the signal to change states (i.e. switch from Off to On or vice versa).

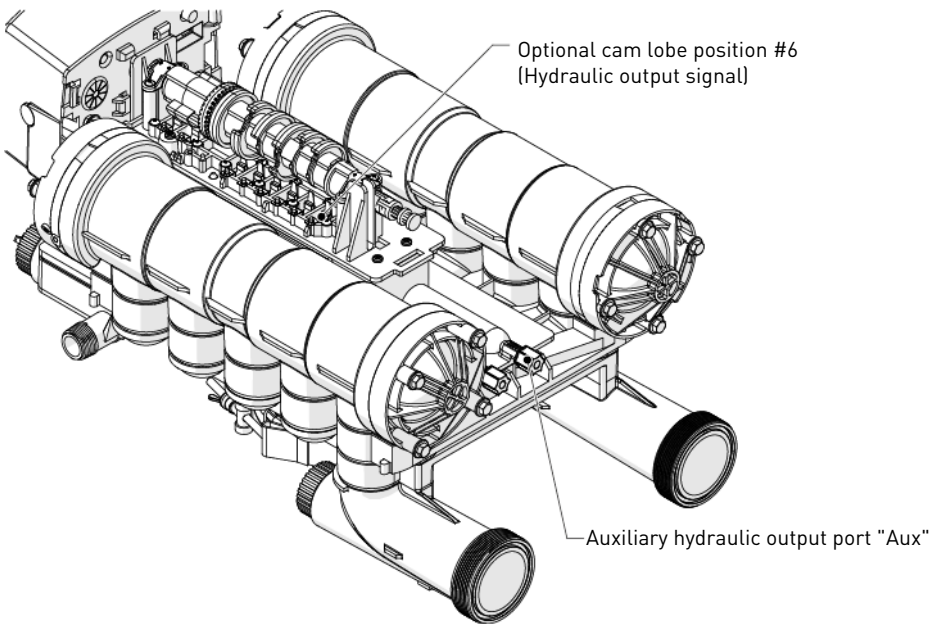

3.6. Systems regeneration cycle

3.6.1. 298 Valves (5 - Cycle softener)

Service — cycle C0

Untreated water is directed down through the resin bed and up through the riser tube. The hardness ions attach themselves to the resin and are removed from the raw water being exchanged on the resin beads towards sodium ions. The water is conditioned as it passes through the resin bed.

Backwash — cycle C1

The flow of water is reversed by the valve and directed down the riser tube and up through the resin bed. During the backwash cycle, the bed is expanded and debris is flushed to the drain, while the media bed is remixed.

Brine — cycle C2

The controller directs water through the brine injector and brine is drawn from the brine tank. The brine is then directed down through the resin bed and up through the riser tube to the drain. The hardness ions are displaced by sodium ions and are sent to the drain. The resin is regenerated during the brine cycle. When the air check valve closes brine drawing finishes, and then the slow rinse phase starts.

Slow rinse — cycle C3

Fast rinse — cycle C5

The controller valve directs water down through the resin bed and up through the riser tube to the drain. Any residual brine is rinsed from the resin bed, while the media bed is re-compacted.

Brine refill — cycle C8

Water is directed to the brine tank at a rate controlled by the refill controller, to create brine for the next regeneration. During brine refill, treated water is already available at the valve outlet.



Note

For illustration purpose only. Always verify inlet and outlet marking on the valve.

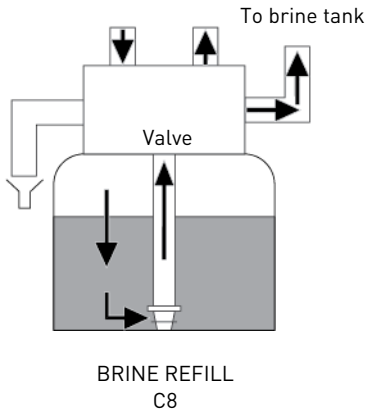
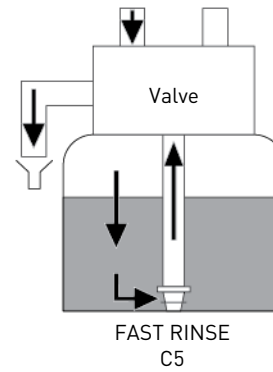
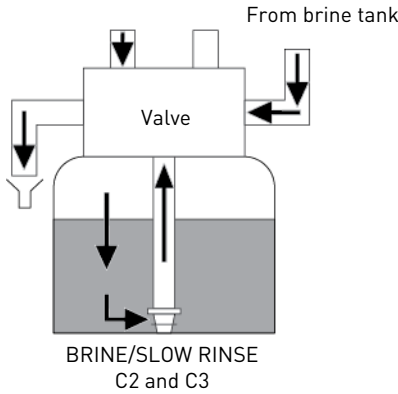
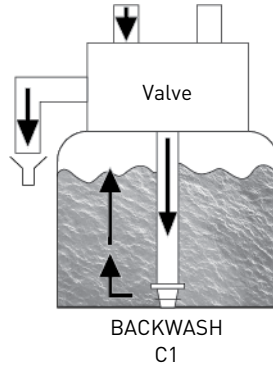
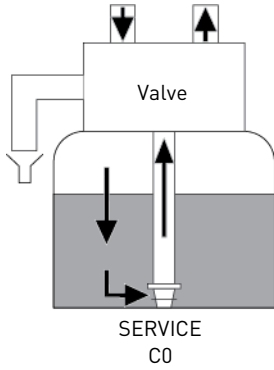

3.6.2. 293 Valves (3 - Cycle filter)

Service — cycle C0

Untreated water is direct down through the conditioning media and up through the riser tube, then out to the system.

Backwash — cycle C1

The flow of water is reversed by the valve and directed down the riser tube and up through the conditioning media. During the backwash cycle, the bed is expanded and debris is flushed to the drain, while the media bed is remixed.

Fast rinse — cycle C5

The controller valve directs water down through the media bed and up through the riser tube to the drain. Media bed is re-compacted inside the tank.



Note

For illustration purpose only. Always verify inlet and outlet marking on the valve.

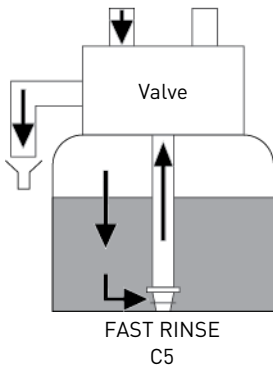
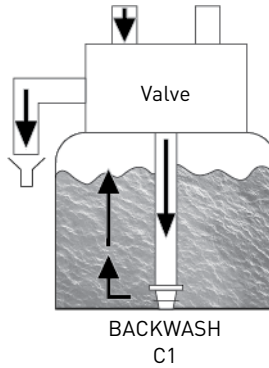
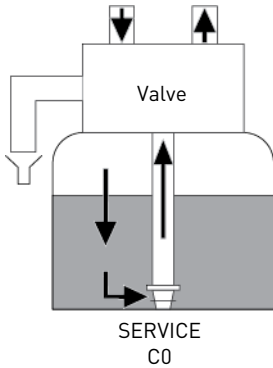

4. System sizing

4.1. Recommendations

4.1.1. Injector and Refill controller charts

Vessel diameter [In]	Injector Flow control [gpm]	Refill flow control [gpm]	Backwash flow control [gpm]
14	0.5	0.7	5.0
16	0.5	0.8	6.0
18	0.6	1.0	8.0
21	0.9	1.4	10.0
24	1.4	2.0	14.0
30	2.0	3.0	21.0
36	3.3	5.0	30.0



Note

All flow rates are based on an inlet pressure of 413 kPa (60 psig). Actual rates vary with pressure, temperatures and other system variables.

4.1.2. Drain line flow control

Flow control disc		Insert 1	Insert 2	Insert 3	Insert 4
[gpm]	[m ³ /h]				
5	1.135	Blue	Black	Black	Black
6	1.362	Red	Black	Black	Black
7	1.589	Brown	Black	Black	Black
8	1.816	Green	Black	Black	Black
9	2.043	White	Black	Black	Black
10	2.27	Blue	Blue	Black	Black
11	2.497	Red	Blue	Black	Black
12	2.724	Red	Red	Black	Black
13	2.951	Brown	Red	Black	Black
14	3.178	Brown	Brown	Black	Black
15	3.405	Blue	Blue	Blue	Black
16	3.632	Green	Green	Black	Black
17	3.859	White	Green	Black	Black

Flow control disc		Insert 1	Insert 2	Insert 3	Insert 4
[gpm]	[m ³ /h]				
18	4.086	White	White	Black	Black
19	4.313	White	Orange	Black	Black
20	4.54	Blue	Blue	Blue	Blue
21	4.767	Brown	Brown	Brown	Black
22	4.994	Green	Green	Red	Black
23	5.221	Green	Green	Brown	Black
24	5.448	Red	Red	Red	Red
25	5.675	Green	Green	White	Black
26	5.902	White	White	Green	Black
27	6.129	White	White	White	Black
28	6.356	Brown	Brown	Brown	Brown
29	6.583	Brown	Brown	Brown	Green
30	6.81	Orange	Orange	Orange	Black
31	7.037	Green	Green	Green	Brown
32	7.264	Green	Green	Green	Green
33	7.491	Green	Green	Green	White
34	7.718	Green	Green	Green	Orange
35	7.945	White	Green	Green	Green
36	8.172	White	White	White	White
37	8.399	White	White	White	Orange
38	8.626	Orange	Orange	Orange	Green
39	8.853	Orange	Orange	Orange	White
40	9.08	Orange	Orange	Orange	Orange



Note

Drain line flow controls above 40 gpm (9.08 m³/h) require external control installed in drain line.

4.1.3. Recommended backwash flow rates for various media

Media	Tank diameter						
	14" (35.6 cm) Tank	16" (40.6 cm) Tank	18" (45.7 cm) Tank	21" (53.3 cm) Tank	24" (61.0 cm) Tank	30" (76.2 cm) Tank	36" (91.4 cm) Tank
Drain line flow control [gpm]							
* Softening Resin (5.0 gpm/ft ²) (12.25 m/h/cm ²)	5	7	9	12	15	25	35
* Fine Mesh Softening resin (2.8 gpm/ft ²) (6.86 m/h/cm ²)	3	4	5	7	9	14	20
Multi Layer (15 gpm/ft ²) (36.75 m/h/cm ²)	15	20	25	36	50	70	105
Birm, Greensand, Carbon (10 gpm/ft ²) (24.5 m/h/cm ²)	10	15	17	25	30	50	70

* 10°C water temperature, 50% bed expansion.

4.2. Cycle time calculation

All the Logix controller range automatically calculates the unit capacity as well as the cycle time. No calculations are therefore required.

4.3. Injector flow rates (tables)

The following tables represent the injectors flow rate as a function of the inlet pressure for the different injector sizes.

Injector 1000441
For 14" Tanks

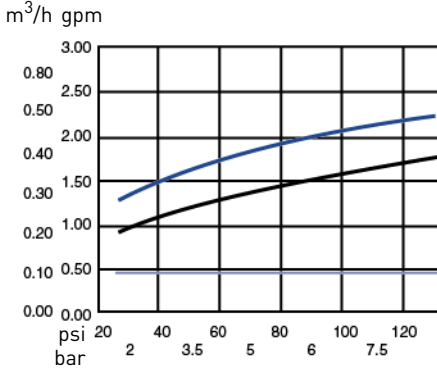

TOTAL — BRINE DRAW — RINSE

Injector 1000442
For 16" Tanks

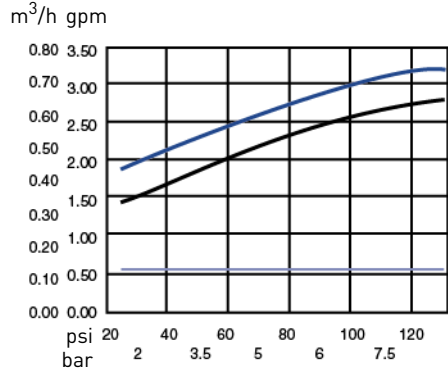

TOTAL — BRINE DRAW — RINSE

Injector 1000443
For 18" Tanks

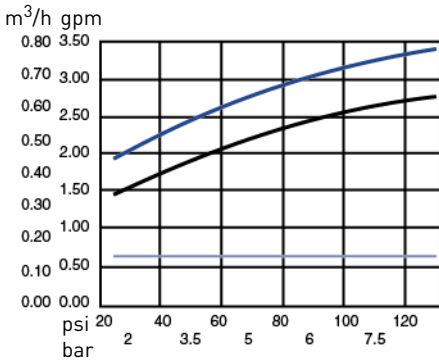

TOTAL — BRINE DRAW — RINSE

Injector 1000444
For 21" Tanks

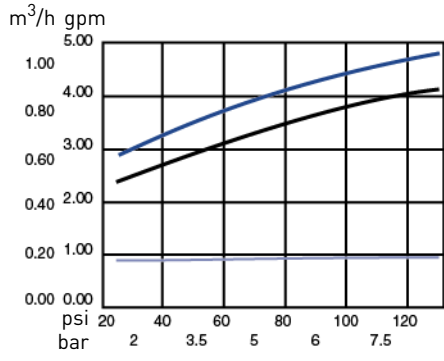

TOTAL — BRINE DRAW — RINSE

Injector 1000445
For 24" Tanks

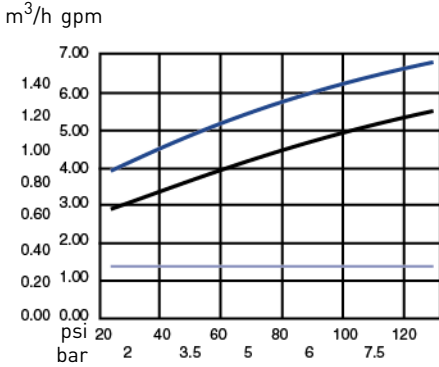

TOTAL — BRINE DRAW — RINSE

Injector 1000446
For 30" Tanks

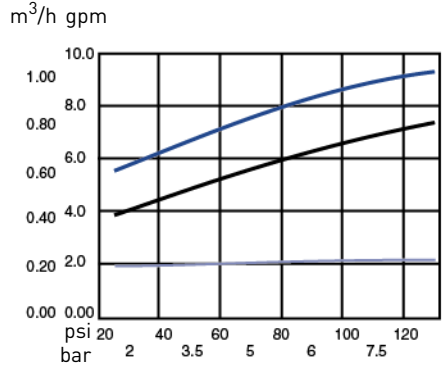

TOTAL — BRINE DRAW — RINSE

Injector 1000447
For 36" Tanks

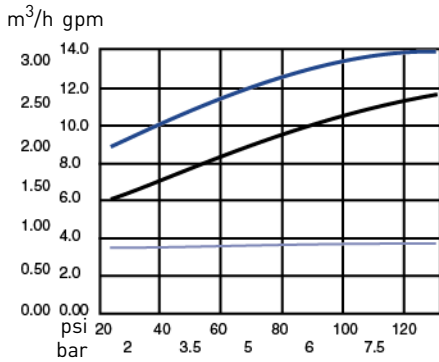

TOTAL — BRINE DRAW — RINSE

4.4. Standard efficiency exchange capacity

Salt [grams / liter]	Exchange capacity [grams / liter]
50	29.9
60	34.0
70	37.5
80	40.6
90	43.4
100	45.9
110	48.2
120	50.2
130	52.1
140	53.8
150	55.5
170	58.5
200	62.7
230	66.9
260	71.0
270	75.3

5. Installation

5.1. Safety notices for installation

- Observe all warnings that appear in this manual.
- Only qualified and professional personnel are authorized to carry out installation work.

5.2. Installation environment

5.2.1. General

- Use only brine salts designed for water softening. Do not use ice melt salt, block, or rock salts.
- Keep the media tank in the upright position. Do not turn on its side, upside down, or drop. Turning the tank upside down may cause media to enter the valve or might plug the upper screen.
- Follow State and local codes for water testing. Do not use water that is micro-biologically unsafe or of unknown quality.
- When filling media tank, first place the control valve in backwash position, then do not open water valve completely. Fill tank slowly to prevent media from exiting the tank.
- When installing the water connection (bypass or manifold) connect to the plumbing system first. Allow heated parts to cool and cemented parts to set before installing any plastic parts. Do not get primer or solvent on O-rings, nuts, or the valve.
- A minimum dynamic operating water pressure of 172 kPa is required for the Magnum control valve to operate properly.

5.2.2. Electrical

There are no user-serviceable parts in the AC transformer, motor, or controller. In the event of a failure, these should be replaced.

- All electrical connections must be completed according to local codes.
- Use only the power AC transformer that is supplied.



Mandatory

The use of any other power transformer than the one supplied void the warranty of all electronic parts of the valve.

- The power outlet must be grounded.
- To disconnect power, unplug the AC/AC transformer from its power source.
- An uninterrupted current supply is required. Please make sure that the voltage supply is compatible with the unit before installation.
- Make sure the controller power source is plugged in.
- If the electrical cable is damaged, it must imperatively be replaced by qualified personnel.

5.2.3. Mechanical

- Do not use petroleum-based lubricants such as vaseline, oils, or hydrocarbon-based lubricants. Use only 100% silicone lubricants.
- All plastic connections should be hand tightened. PTFE (plumber's tape) may be used on connections that do not use an O-ring seal. Do not use pliers or pipe wrenches.
- All plumbing must be completed according to local codes.
- Soldering near the drain line should be done before connecting the drain line to the valve. Excessive heat will cause interior damage to the valve.
- Observe the drain line requirements:
Maximum 1 m (3 ft 3 in) high at 2 bars (29 psi) inlet pressure. Add 50 cm (1 ft 7 in) for each additional 1 bar (14.5 psi) inlet pressure.
- Do not use lead-based solder for sweat solder connections.
- To prevent mineral loss during backwash and to ensure proper operation of the valve, a drain line flow control must be plumbed into the drain line prior to placing the valve in service mode. Flow controls from 18.92 to 151.4 L/min can be easily installed in the drain line. Flow controls greater than 151.4 L/min must be plumbed externally. The selection of the proper drain line flow control depends on the tank size and media used for the installation.
- The drain line must be a minimum of 12.7 mm (½") in diameter. Use 19 mm (¾") pipe if the backwash flow rate is greater than 26.5 lpm (5.83 gpm) or the pipe length is greater than 6 m (19 ft 8 in).
- Do not support the weight of the system on the control valve fittings, plumbing, or the bypass.
- It is not recommended to use sealants on the threads. Use PTFE (plumber's tape) on the threads of the 25.4 mm (1") NPT elbow, the drain line connections, and other NPT/BSP threads.

5.2.4. Outdoor Locations

When the water conditioning system is installed outdoors, several points must be considered.

- Moisture — The valve and 700 controller are rated for NEMA 3 locations. Falling water should not affect performance. The system is not designed to withstand extreme humidity or water spray from below. Examples are: constant heavy mist, near corrosive environment, upwards spray from sprinkler.
- Direct Sunlight — The materials used will fade or discolour over time in direct sunlight. The integrity of the materials will not degrade to cause system failures.
- Temperature — Extreme hot or cold temperatures may cause damage to the valve or controller. Freezing temperatures will freeze the water in the valve. This will cause physical damage to the internal parts as well as the plumbing. High temperatures will affect the controller. The display may become unreadable but the controller should continue to function. When the temperature drops back into normal operating limits the display will return to normal. A protective cover (P/N 1267811) should assist with high temperature applications.
- Insects — The controller and valve have been designed to keep all but the smallest insects out of the critical areas. Any holes in the top plate can be covered with a metal foil ductwork tape. The top cover should be installed securely in place.
- Wind — The Logix cover is designed to withstand a 48 km/h (30 mph) wind when properly installed on the valve.

5.3. Integration constraints

Location of a water treatment system is important. The following conditions are required:

- Level platform or floor;
- Room to access equipment for maintenance and adding brine (salt) to tank;
- Constant electrical supply to operate the controller;
- Total minimum pipe run to water heater of 3 m (10 ft) to prevent backup of hot water into system;
- Always install check valve to protect the softener from hot water return;
- Local drain for discharge as close as possible;
- Water line connections with shut off or bypass valves;
- Must meet any local and state codes for site of installation;
- Valve is designed for minor plumbing misalignments. Do not support weight of system on the plumbing;
- Be sure all soldered pipes are fully cooled before attaching plastic valve to the plumbing.

5.4. Block diagram and configuration example

Block diagram

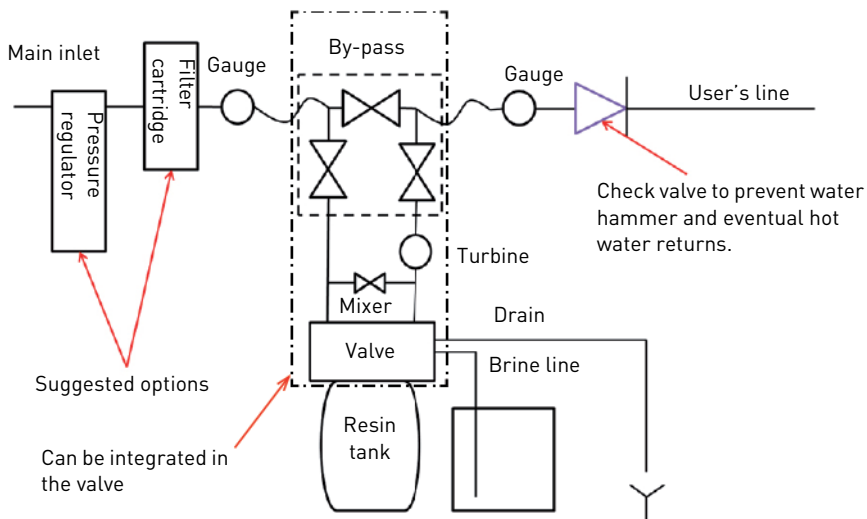

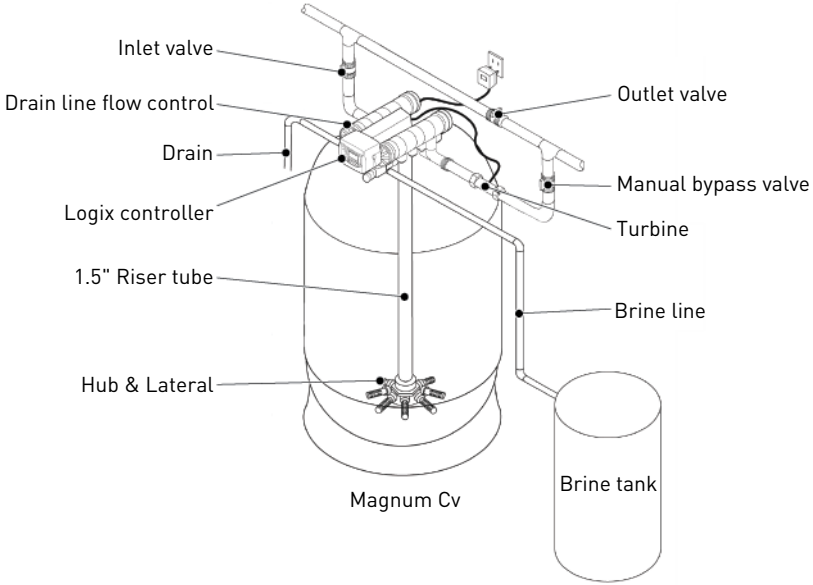

Configuration example

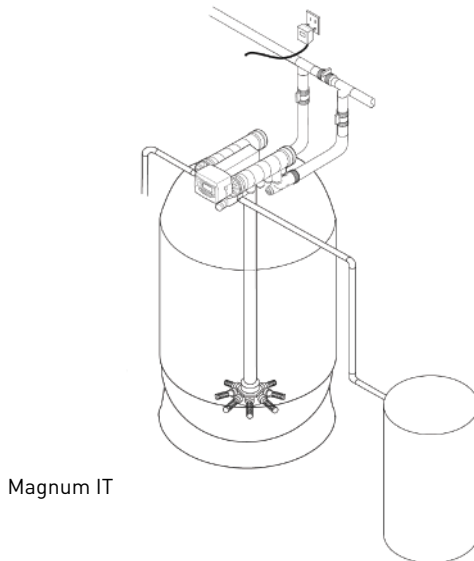

Magnum IT

5.5. Valve connection to piping

The connections should be hand tightened using PTFE (plumber's tape) on the threads if using the threaded connection type.

In case of heat welding (metal type connection), the connections should not be made to the valve when soldering.



Note

See chapter 3.4. Description and components location, page 15 to identify the connections.

5.5.1. Top-mounted valve installation

When pressurized, any composite tank will expand both vertically and circumferential. In order to compensate the vertical expansion, the piping connections to the valve must be flexible enough to avoid overstress on the valve and tank.

In addition, the valve and tank should not be supporting any part of the piping weight. This is hence compulsory to have the piping fixed to a rigid structure [e.g. frame, skid, wall...] so that the weight of it is not applying any stress on the valve and tank.

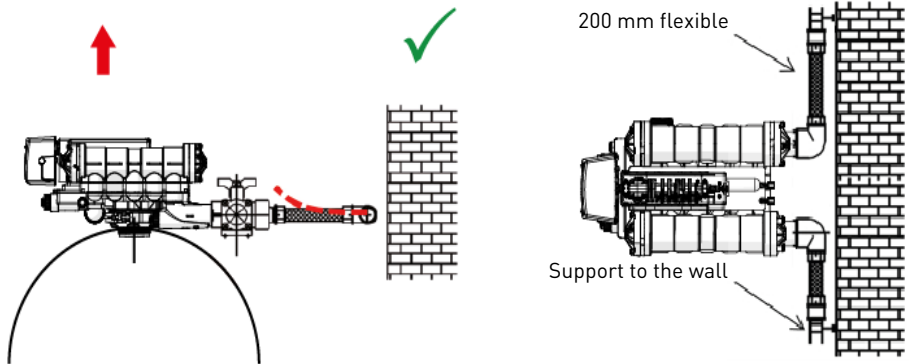

- The diagrams above illustrate how the flexible piping connection should be mounted.
- In order to adequately compensate the tank elongation the flexible tubes must be installed horizontally.
- Should the flexible piping connection be installed in vertical position, instead of compensating the elongation, it will create additional stresses on the valve & tank assembly. Therefore this is to be avoided.
- The flexible piping connection must be also be installed stretched, avoiding excessive length. For instance 20 - 40 cm is enough.
- Excessively long and non-stretched flexible piping connection will create stresses on the valve and tank assembly when the system is pressurized, as illustrated in the below picture: on the left the assembly when the system is unpressurised, on the right the flexible piping connection when put under pressure tends to lift up the valve when stretching up. This configuration is even more dramatic when using semi-flexible piping.

- Failure to provide enough vertical compensation may lead to different kinds of damage, either on the valve thread which connects to the tank, or on the female thread connection of the tank that connects to the valve. In some cases, damage may also be seen on the valve inlet and outlet connections.

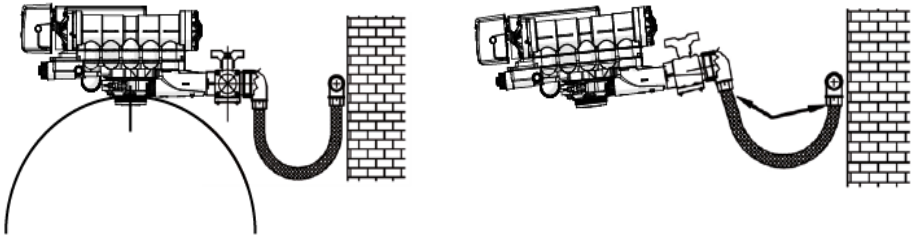

- In any case, any failure caused by improper installations and/or piping connections may void the warranty of Pentair products.
- In the same way, using lubricant* on the valve thread is not allowed and will void the warranty for the valve and tank. Indeed using lubricant there will cause the valve to be over-torqued, which may lead to valve thread or tank thread damage even if the connection to piping has been done following the above procedure.

*Note: Use of petroleum-based grease and mineral based lubricant is totally forbidden, not only on the valve thread, since plastics (especially Noryl) will highly suffer from contact with this type of grease, leading into structural damage hence to potential failures.

5.5.2. Side-mounted valve installation

Use a 2" BSP side mount adapter assembly for the installation.

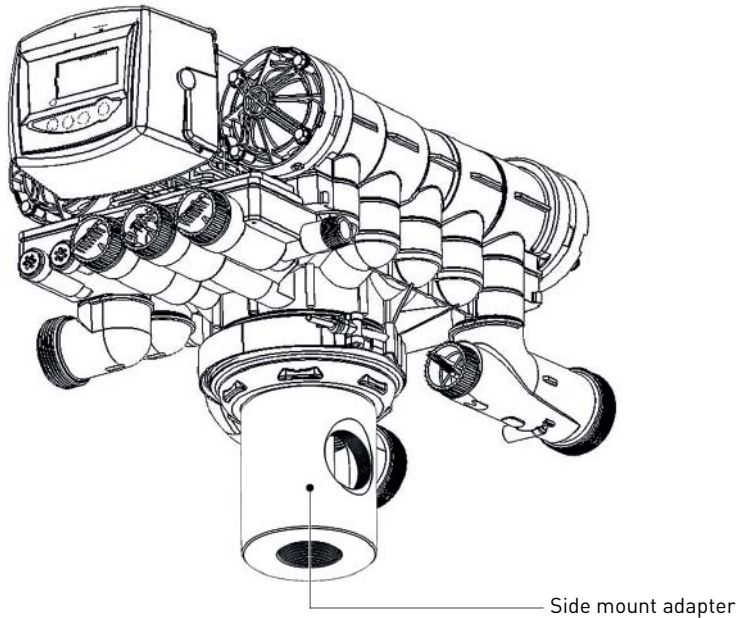

- Valid for location having a reduced height.
- To avoid the piping supporting the valve and side adapter weight, they must be fixed on a tripod or any other appropriate support.
- In order to adequately compensate the tank elongation, the rubber expansion joints must be mounted on the top and bottom of the tank.



Caution

Respect the heights given by the manufacturer.

5.6. Connections (electrical)

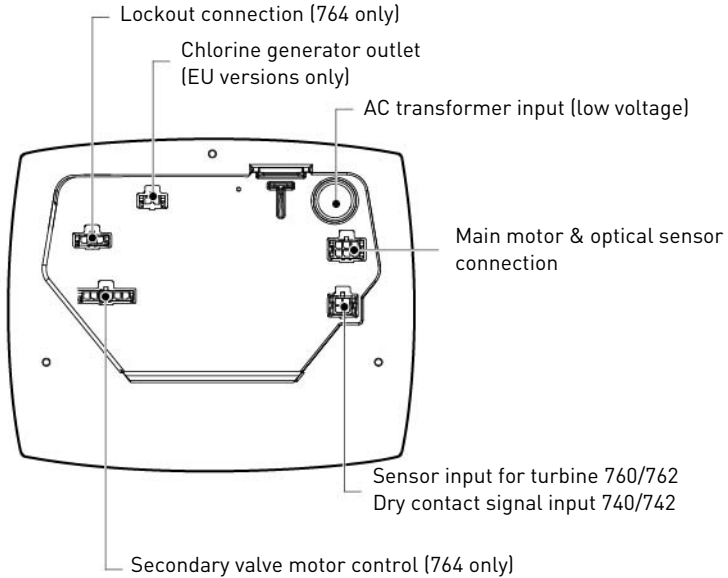

5.7. Bypassing

A bypass valve system should be installed on all water conditioning systems. Bypass valves isolate the softener from the water system and allow unconditioned water to be used. Service or routine maintenance procedures may also require that the system is bypassed.

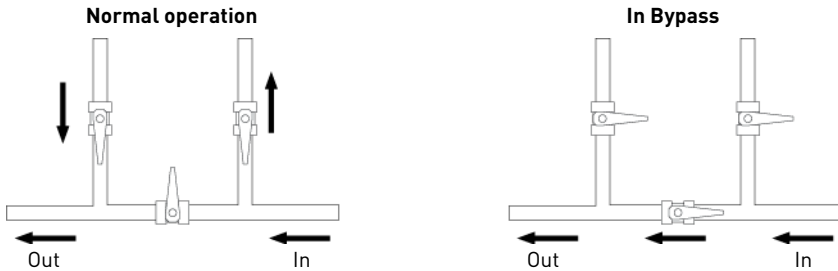

Caution

Do not solder pipes with lead-based solder.



Caution

Do not use tools to tighten plastic fittings. Over time, stress may break the connections.



Caution

Do not use petroleum grease on gaskets when connecting bypass plumbing. Use only 100% silicone grease products when installing any plastic valve. Non-silicone grease may cause plastic components to fail over time.

5.8. Drain line connection



Note

Standard commercial practices are expressed here. Local codes may require changes to the following suggestions. Check with local authorities before installing a system.



Mandatory

The drain line must be build with 1.5" PVC rigid tube with an air gap must be present at the drain.



Caution

Flexible and semi-flexible hoses may bend and whip during draining.

The drain line must be build with 1.5" PVC rigid tube with an air gap.

The drain line may be elevated up to 1.8 m providing the run does not exceed 4.6 m and water pressure at the softener is not less than 2.76 bar. Elevation can increase by 61 cm) for each additional 0.69 bar of water pressure at the drain connector.

Where the drain empties into an overhead sewer line, a sink-type trap must be used.

Secure the end of the drain line to prevent it from moving.



Note

Waste connections or the drain outlet shall be designed and constructed to provide connection to the sanitary waste system through an air-gap of 2 pipe diameters or 76.2 mm (3"), whichever is larger.



Caution

Never insert the drain line directly into a drain, sewer line or trap. Always allow an air gap between the drain line and the wastewater to prevent the possibility of sewage being back-siphoned into the softener.

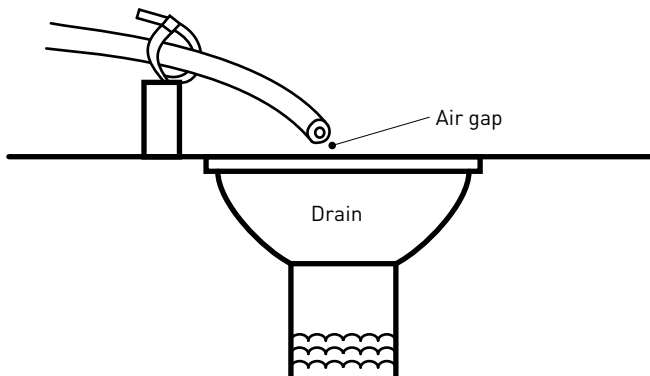

5.9. Overflow line connection

In the event of a malfunction, the brine tank overflow fitting will direct "overflow" to the drain instead of spilling on the floor. This fitting should be on the side of the cabinet or brine tank. Most tank manufacturers include a post for the tank overflow connector.

To connect the overflow line, locate the hole on side of tank. Insert overflow fitting into tank and tighten with plastic thumb nut and gasket as shown below. Attach a length of 12.7 mm (1/2") I.D. tubing (not supplied) to fitting and run to drain.

Do not elevate overflow higher than overflow fitting.

Do not tie into drain line of controller unit. Overflow line must be a direct, separate line from overflow fitting to drain, sewer or tub. Allow an air gap as per drain line instructions.

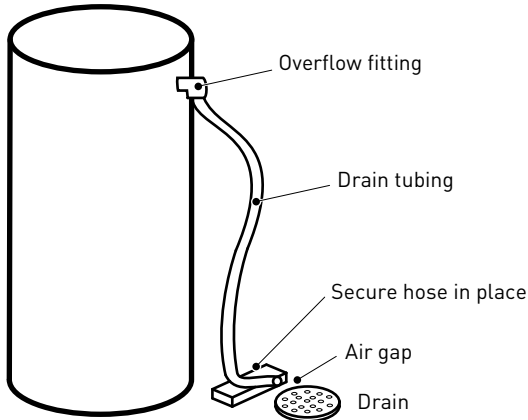

Caution

Floor drain is always recommended to avoid flooding in case of overflow.

6. Programming

6.1. Display

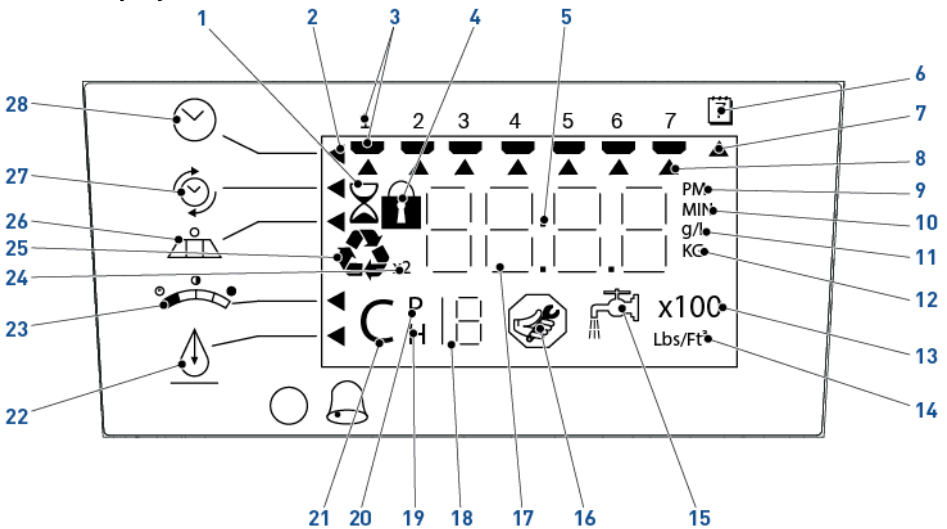



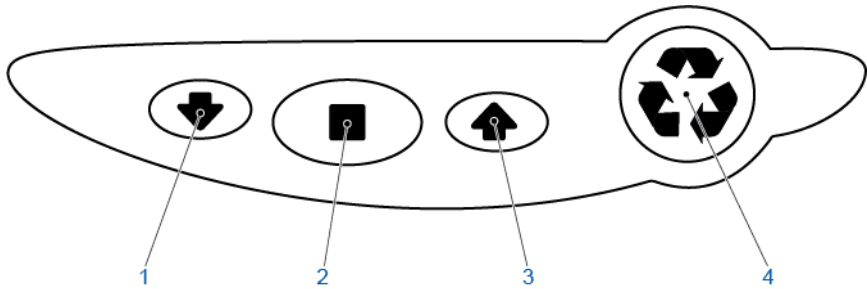

- | | |
|--------------------------------|---|
| 1. Hourglass | Displayed when the motor is running. The camshaft should be turning. |
| 2. Cursor | These cursors appear next to the item that is currently displayed. |
| 3. Days of the week | Displayed days of the week. The flag below the day appears when that day has been programmed as a day the system should regenerate (used with 7-day timer programming). |
| 4. Locked / unlocked indicator | This symbol is display in basic programming when the current parameter is locked-out.
It is also used in advanced programming to indicate if the displayed parameter is locked when the controller is in basic programming (the icon flashes). |
| 5. Colon | Colon flashes as part of the time display.
It also indicates normal operation (742 only). |
| 6. Indicator | Indicator for day regeneration programming. |
| 7. Cursor | This cursor is displayed when the days between regeneration are being programmed (used with 0.5 to 99 day regeneration programming) |
| 8. Cursor | One of these cursor is displayed to indicate which day is programmed into the controller. |
| 9. "PM" | Indicates that the time displayed is between 12:00 noon and 12:00 midnight.
"PM" indicator is not used if the clock mode is set to 24-hour (there is no AM indicator). |
| 10. "MIN" | Indicates that the value entered / displayed is in minute increments. |

11. "g/L"	Indicates that the value entered / displayed is in grams / Liter.
12. "KG"	Indicates that the value entered / displayed is in kilograms or kilograins.
13. "x100"	x100 multiplier for large values.
14. "Lbs/ft ³ "	Indicates that the value entered / displayed for regenerant amount is in pounds per cubic foot.
15. Faucet	Appears when the current flow rate is displayed. The controller may show the faucet and "0", indicating no flow.
16. Maintenance interval	Displayed when the month in service exceed the value programmed in parameter P11.
17. Digits	Four digits used to display the time, program value or error codes.
18. Number	Used with #19, #20 and #21. Displays a sequence number or value.
19. History values (H)	The number displayed by #18 identifies which history value is currently displayed.
20. Parameter (P)	Displayed only in advanced programming. The number displayed by #18 identifies which parameter is currently displayed.
21. Cycle (C)	The number displayed by #18 is the current cycle in the regeneration sequence.
22. Hardness	Hardness setting - only used with 760 and 762 controllers.
23. Capacity	Shows estimated system capacity.
24. "x2"	Indicates a second regeneration has been called for.
25. Recycle sign	Flashes when a regeneration at the next time of regeneration has been called for. Also displayed (continuously) when in regeneration.
26. Salt	Programming the amount of regenerant. If the controller is on a 3-cycle filter then the backwash time is displayed.
27. Regeneration time and day	Programming the time of regeneration and the days of regeneration.
28. Time and day	Programming the current time and day.

6.2. Commands



- | | |
|---|---|
| <ol style="list-style-type: none"> 1.  - Down arrow 2.  - Set 3.  - Up arrow 4.  - Regenerate | <p>Scrolls down or decrement through a group of choices.</p> <p>Accepts a setting that normally becomes stored in memory. Also used together with the arrow buttons to access special features.</p> <p>Scrolls up or increment through a group of choices.</p> <p>Commands the controller to regenerate. Also used to change the lock mode.</p> |
|---|---|

6.3. Basic programming



Note

At any time, press to return to the home screen.



Note

Menus are displayed in a defined and incremental order.

6.3.1. Basic programming 742 - 762 / 298 valve type

6.3.1.1 Program valve type

Set your valve type through the options.

- A Use and to scroll through valve type choices.
→ Valve type flashes.
- B Choose the 298 valve type.
- C Press to validate the valve type selected and advance to the next parameter using or .

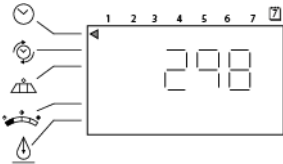

6.3.1.2 Program system size

Set your input system size and your resin volume in litres.

- A Use and to scroll through resin volume choices.
→ Three dashes than resin volume flashes.
- B Choose the nearest volume to your actual system size.
- C Press to validate the system size selected and advance to the next parameter using or .
- D If an incorrect setting is programmed, see "Resetting the controller", page 57.

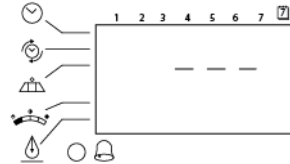

6.3.1.3 Time setting

Set the current time.

- A Press .
→ Time flashes.
- B Adjust displayed time with and .
- C Press to validate the selection and advance to the next parameter using or .

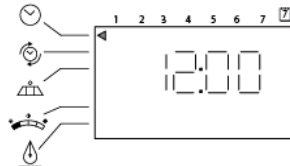

6.3.1.4 Day of week

Set the current day of the week.

- A** Press **■**.
→ Arrow flashes.
- B** Select displayed day with **▲** and **▼**.
- C** Press **■** to validate the selection and advance to the next parameter using **▼** or **▲**.

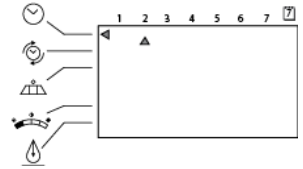

6.3.1.5 Regeneration time

Set the time when regeneration will take place.

- A** Press **■**.
→ Regeneration time flashes.
- B** Adjust displayed time with **▲** and **▼**.
→ Default setting: 2:00 am.
- C** Press **■** to validate the selection and advance to the next parameter using **▼** or **▲**.

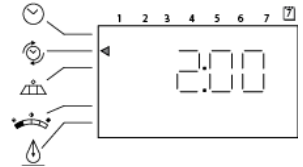

6.3.1.6 Days override (762 controller only)

Set the number of days for calendar override.

- A** Press **■**.
→ Number of days flashes.
- B** Adjust displayed number with **▲** and **▼**.
→ Default time for days override: 0 day (disabled).
→ Days can be adjusted from 1/2 (.5) to 99 days.
- C** Press **■** to validate the selection and advance to the next parameter using **▼** or **▲**.

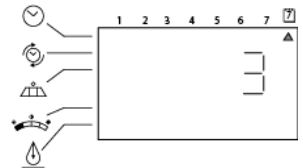

6.3.1.7 Days between regeneration (742 controller only)

Set the number of days between regeneration.

- A** Press **■**.
→ Number of days flashes.
- B** Adjust displayed number with **▲** and **▼**.
→ Set to 0 to program as a 7-day timer.
→ Days can be adjusted from 1/2 (.5) to 99 days.
- C** Press **■** to validate the selection and advance to the next parameter using **▼** or **▲**.

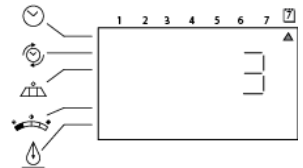

6.3.1.8 Amount of brine used per regeneration

Set desired brine amount in g/L.

- A** Press .
→ Setting flashes.
- B** Adjust displayed settings with and .
- C** Press to validate the selection and advance to the next parameter using or .

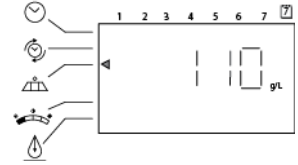

6.3.1.9 Estimated capacity



Note

The system capacity is displayed in kilograms equivalent CaCO_3 of hardness removed before a regeneration is necessary.



Note

The capacity is calculated by the Logix software, using the resin volume, brine dosage and hardness settings.



Note

This parameter can be override for 762 controller and is view only for 742 controller.

Set the estimated capacity on the controller.

- A** Press .
→ The amount number flashes.
- B** Adjust displayed capacity with and .
- C** Press to validate the selection and advance to the next parameter using or .

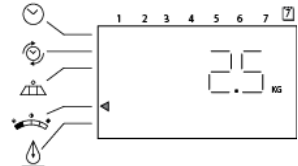

6.3.1.10 Hardness (762 controller only)

Set inlet water hardness at installation site.



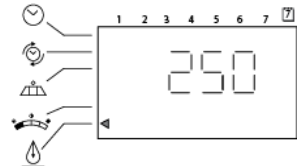

- A** Press .
→ The hardness number flashes.
- B** Adjust displayed hardness number with and .
- C** Press to validate the selection.
→ Initial programming is now complete. The controller will return you to the normal operation mode.



6.3.2. Basic programming 742F - 762F / 293 valve type

6.3.2.1 Program valve type



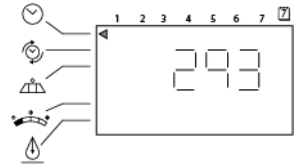

Set your valve type through the options.

- A Use  and  to scroll through valve type choices.
→ Valve type flashes.
- B Choose the 293 valve type.
- C Press  to validate the system size selected and advance to the next parameter using  or .



6.3.2.2 Program system size





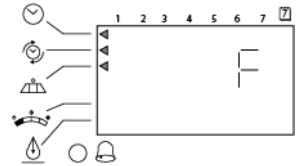

Set your system in filter configuration.

- A Use  and  to scroll through resin volume choices.
→ Three dashes than resin volume flashes.
- B Select "F" to validate the system as a filter configuration.
- C Press  to validate the system size and advance to the next parameter using  or .
- D If an incorrect setting is programmed, see "Resetting the controller", page 57.



6.3.2.3 Time setting





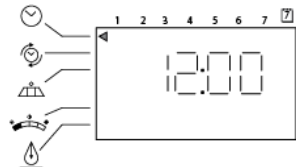

Set the current time.

- A Press .
→ Time flashes.
- B Adjust displayed time with  and .
- C Press  to validate the selection and advance to the next parameter using  or .



6.3.2.4 Day of week

Set the current day of the week.

- A Press .
→ Arrow flashes.
- B Select displayed day with  and .
- C Press  to validate the selection and advance to the next parameter using  or .

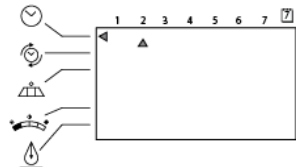

6.3.2.5 Time of backwash

Set the time of backwash cycle [C1].

- A Press .
→ Backwash time flashes.
- B Adjust displayed time with and .
- C Press to validate the selection and advance to the next parameter using or .

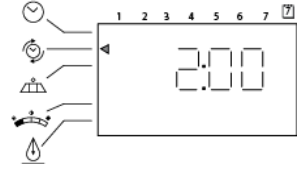

6.3.2.6 Days override (762F controller only)

Set the number of days for calendar override.

- A Press .
→ Number of days flashes.
- B Adjust displayed number with and .
- Default time for days override: 0 day (disabled).
→ Days can be adjusted from ½ (.5) to 99 days.
- C Press to validate the selection and advance to the next parameter using or .

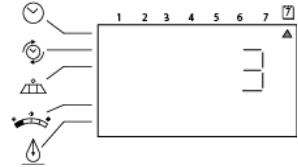

6.3.2.7 Days between regeneration (742F controller only)

Set the number of days between regeneration.

- A Press .
→ Number of days flashes.
- B Adjust displayed number with and .
- Set to 0 to program as a 7-day timer.
→ Days can be adjusted from ½ (.5) to 99 days.
- C Press to validate the selection and advance to the next parameter using or .

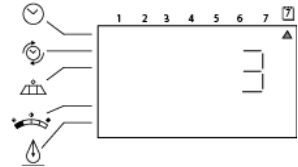

6.3.2.8 Backwash length

Set the backwash length in minutes.

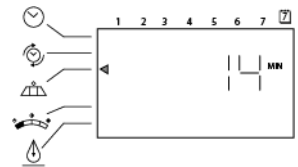

- A Press .
→ Time flashes.
- B Adjust displayed time with and .
- C Press to validate the selection and advance to the next parameter using or .



6.4. Advanced programming



Note

Press and hold  +  for 5 seconds to access advance programming. A "P" symbol is displayed on the bottom left of screen.

6.4.1. Basic programming parameters (5 - Cycle softener system)

Parameter description		Range of values	Default value	Units of measure	Notes
P1	Time of day	1:00 - 12:59AM 0:00 - 23:59PM	12:00 PM	Hour : minute	Range depends on value selected for P10.
P2	Day of week	N/A	None	N/A	-
P3	Time of regeneration	1:00 - 12:59AM 0:00 - 23:59PM	2:00 AM	Hour : minute	Range depends on value selected for P10.
P4	Calendar override	0 - 99	3	Days	0 = no calendar override. 0.5 = regeneration twice a day at time of regeneration and 12 hours later. Calendar override skipped if at least one day of regeneration selected.
P5	Day of week regeneration	N/A	None	N/A	Day of week regeneration is skipped if calendar override is more than 0 (742 controller only).
P6	Salt setting	50 - 290	110	g/l	Unit of measure depends on value selected for P9.
P7	Capacity of unit	0.1 - 90	*	kg	Unit of measure depends on value selected for P9.
P8	Hardness of water	30 - 2000	400	g/l	Unit of measure depends on value selected for P9 (762 controller only).

* Calculated depending on salt setting and resin volume. The capacity may be manually adjusted.

6.4.2. Advanced programming parameters (5 - Cycle softener system)

Parameter description		Range of values	Default value	Units of measure	Notes
P9	Units of measure	0 - 1	**	N/A	0 = US unit. 1 = Metric unit.
P10	Clock mode	0 - 1	**	N/A	0 = 12 hour clock. 1 = 24 hour clock.
P11	Service interval	0 - 250	0	Months	Uses 30 days for each months.
P12	Remote regeneration	3 - 250	0	Months	Time remote switch must be active to start regeneration on 742 controller.
P13	Chlorine generator options	0 - 2	0	N/A	0 = no chlorine generator. 1 = salt check only. 2 = generate chlorine.
P14	Refill rate	1 - 700	*	gpm x 100	-
P15	Draw rate	1 - 700	*	gpm x 100	-
P16	Reserve type	0 - 3	0	N/A	0 = variable reserve delayed regeneration. 1 = fixed reserve delayed regeneration. 2 = variable reserve immediate regeneration. 3 = fixed reserve immediate regeneration.
P17	Initial average or fixed reserve	0 - 70	30	% of capacity	Depends on value selected for P16.
P18	Flow sensor select	0 - 5	*	N/A	0 = internal Magnum NHWB. 1 = 1" Autotrol turbine. 2 = 2" Autotrol turbine. 3 = User defined. K-factor, 4 = User defined pulse equivalent. 5 = internal Magnum HWB.
P19	K-factor or pulse equivalent	1.00 - 99.99 0 - 9999	0.01 1	N/A	K-factor P18 = 3. Pulse equivalent P18 = 4.

* Default value selected with valve type and resin volume.

** Factory default value is "0" for North America and "1" for World units.



Note

Parameters P16 to P19 are skipped on 742 controller.

6.4.3. Basic programming parameters (3 - Cycle filter system)

Parameter description		Range of values	Default value	Units of measure	Notes
P1	Time of day	1:00 - 12:59AM 0:00 - 23:59PM	12:00 PM	Hour : minute	Range depends on value selected for P10.
P2	Day of week	N/A	None	N/A	-
P3	Time of regeneration	1:00 - 12:59AM 0:00 - 23:59PM	2:00 AM	Hour : minute	Range depends on value selected for P10.
P4	Calendar override	0 - 99	3	Days	0 = no calendar override. 0.5 = regeneration twice a day at time of regeneration and 12 hours later. Calendar override skipped if at least one day of regeneration selected.
P5	Day of week regeneration	N/A	None	N/A	Day of week regeneration is skipped if calendar override is more than 0 (742 controller only).
P6	Backwash time	1 - 250	14	Minutes	-
P7	Capacity of unit	1 - 900	*	m ³	Unit of measure depends on value selected for P9.
P8	-	-	-	-	Skipped for 3 - cycle filter configuration.

* Default value selected with valve type and resin volume.

6.4.4. Advanced programming parameters (3 - Cycle filter system)

Parameter description		Range of values	Default value	Units of measure	Notes
P9	Units of measure	0 - 1	**	N/A	0 = US unit. 1 = Metric unit.
P10	Clock mode	0 - 1	**	N/A	0 = 12 hour clock. 1 = 24 hour clock.
P11	Service interval	0 - 250	0	Months	Uses 30 days for each months.
P12	Remote regeneration	3 - 250	60	Seconds	Time remote switch must be active to start regeneration on 742 controller.
P13	-	-	-	-	Skipped for 3 - cycle filter configuration.
P14	-	-	-	-	Skipped for 3 - cycle filter configuration.
P15	-	-	-	-	Skipped for 3 - cycle filter configuration.
P16	Reserve type	0 - 3	0	N/A	0 = variable reserve delayed regeneration. 1 = fixed reserve delayed regeneration. 2 = variable reserve immediate regeneration. 3 = fixed reserve immediate regeneration.
P17	Initial average or fixed reserve	0 - 70	30	% of capacity	Depends on value selected for P16.
P18	Flow sensor select	0 - 5	*	N/A	0 = internal Magnum NHWB. 1 = 1" Autotrol turbine. 2 = 2" Autotrol turbine. 3 = User defined. K-factor, 4 = User defined pulse equivalent. 5 = internal Magnum HWB.
P19	K-factor or pulse equivalent	1.00 -99.99 0 - 9999	0.01 1	N/A	K-factor P18 = 3. Pulse equivalent P18 = 4.

* Default value selected with valve type and resin volume.



** Factory default value is "0" for North America and "1" for World units.







Note

Parameters P16 to P19 are skipped on 742 controller.

6.4.5. Cycle time programming

Press and hold the  and  for 5 seconds when the controller is not in regeneration to enter cycle time programming.

- A small "C#" with a number will be displayed indicating the controller is in cycle time programming.
- The number indicates the cycle being viewed or changed.
- Cycle times are programmable from 0 to 200 minutes.

- A** Press .
→ Cycle time flashes.
- B** Adjust displayed time with  and .
- C** Press  to validate the selection.
→ The next cycle time is displayed.

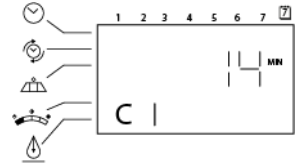

Note

The draw and refill cycle times (C2 & C8) can not be changed in cycle time programming for 5 - cycle softener system. They are calculated using the draw and refill rates and the salt amounts.

Magnum valves 293 / 298		
Description	Default value [min]	C# displayed
Backwash	14	1
Draw ⁽¹⁾	(3)	2 ⁽²⁾
Slow rinse	(4)	3 ⁽²⁾
Fast rinse	6	5
Refill ⁽¹⁾	(5)	8

(1) Can only be programmed in 3 - cycle filter configuration.

(2) Separate draw and rinse positions are present on Magnum cam. The controller stays in the brine draw position for both draw and rinse times then it proceeds through the rinse position with no dwell time.

(3) Depends on valve type and resin volume. Time is calculated from total salt amount and draw rate.

(4) Depends on valve type, resin volume and rinse rate. Time is calculated for two bed volume on 298 valves.

(5) Depends on valve type and resin volume. Time is calculated from total salt amount and refill rate.

6.4.6. Diagnostic

To access diagnostic values, press and hold  and  for 5 seconds to view the "H" levels.





Diagnostic Code	Description	Unit	Range	762	742																													
H0	Initial setting value	Litre	Resin Volume	Yes	Yes																													
H1	Days since last regeneration	N/A	0 - 255		Yes	No																												
H2	Current flow rate	Depends on turbine used					Yes	No																										
H3	Water used today since time of regeneration	m ³	0 - 61310.70						Yes	No																								
H4	Water used since last regeneration	m ³	0 - 61310.70								Yes	No																						
H5	Total water used since reset in 100 s	m ³	0 - 9999										Yes	No																				
H6	Total water used since reset in 1000000 s	m ³	4264 x 10 ⁴												Yes	No																		
H7	Average usage for Sunday	m ³	0 - 61310.70														Yes	No																
H8	Average usage for Monday	m ³	0 - 61310.70																Yes	No														
H9	Average usage for Tuesday	m ³	0 - 61310.70																		Yes	No												
H10	Average usage for Wednesday	m ³	0 - 61310.70																				Yes	No										
H11	Average usage for Thursday	m ³	0 - 61310.70																						Yes	No								
H12	Average usage for Friday	m ³	0 - 61310.70																								Yes	No						
H13	Average usage for Saturday	m ³	0 - 61310.70																										Yes	No				
H14	Average service cycle	Day	0 - 255																												Yes	No		
H15	Peak flow rate	l/min	0 - 1000																														Yes	No
H16	Day and time of peak flow rate	Time and day that peak flow occurred																																
H17	Months since service	Month	0 - 2184	Yes		Yes																												
Hr	Number of regenerations since last service	N/A	0 - 65536		Yes																													

6.4.7. Resetting the controller

**Caution**

Resetting the controller will delete all information stored in its memory, except the time and day. This will require you to reprogram the controller completely from the initial power-up mode.

To reset the controller:

- A** Press and hold  and  for 5 seconds.
→ H0 and the system's set resin volume (or "F" mode) will be displayed.
- B** If a history value other than "H0" is displayed, use  to scroll through the settings until "H0" is displayed.
- C** To reset the controller, press and hold  for 5 seconds.
→ The controller will be reset to an unprogrammed state.
- D** Go to Chapter 6. Programming, page 43 to reprogram the controller.

7. Commissioning



Note

This chapter is available for standard regeneration types. Contact your supplier if the actual regeneration is not standard and if you need assistance.

7.1. Water filling, draining and waterproofness inspection

7.1.1. Activating the softener



After you have performed the previous initial programming steps, you will need to activate the softener.



Caution

Do not rotate the camshaft by hand or damage to the unit may occur. Use the controller to take the camshaft electronically through the cycles.

Follow these steps carefully:

1. Remove the cover from the valve. Removing the cover will allow you to see that the camshaft is turning, and in which cycle the camshaft is currently positioned.
2. With the supply water for the system still turned off, position the bypass valve to the "non-bypass" (normal operation) position.
3. Press  on the controller for 5 seconds. This will initiate a manual regeneration. The controller will indicate that the motor is turning the camshaft to cycle C1 (Backwash) position by flashing an hourglass. The controller will display the total regen time remaining. If you press and hold the  button, the controller will indicate the time remaining in the current cycle.
4. Fill the media tank with water.
 - While the controller is in cycle C1 (Backwash), open the water supply valve very slowly to approximately the $\frac{1}{4}$ open position.



Caution

If opened too rapidly or too far, media may be lost out of the tank into the valve or the plumbing. In the $\frac{1}{4}$ open position, you should hear air slowly escaping from the valve drain line.



- When all of the air has been purged from the media tank (water begins to flow steadily from the drain line), open the main supply valve all of the way. This will purge the final air from the tank.
- Allow water to drain out until the water runs clear from the drain line. This purges any refuse from the media bed.
- Turn off the water supply and let the system stand for about 5 minutes. This will allow any trapped air to escape from the tank.

5. Add water to the brine tank (initial fill) (softener and 3-cycle filters only).
 - With a bucket or hose, add approximately 15 liters (4 gallons) of water to the brine tank. If the tank has a salt platform in the bottom of the tank, add water until the water level is approximately 25 mm (1") above the platform.
-

Note

We recommend that you do not put salt into the tank before the control valve has been started up. With no salt in the tank, it is much easier to view water flow and motion.

6. Engage the refill cycle to prime the line between the brine tank and the valve (softener only).
 - Slowly open the main water supply valve again, to the fully open position. Be sure not to open too rapidly as that would push the media out of the media tank.
 - Advance the controller to the Refill (C8) position. From cycle C1 (Backwash), press and hold . This will display the current cycle.

While pressing , press  to advance to the next cycle. Continue to advance through each cycle until you have reached cycle C8 (Refill).

Note

As you advance through each cycle there will be a slight delay before you can advance to the next cycle. The hourglass icon will be lit while the camshaft is indexing.



→ With the water supply completely open, when the valve reaches C8 (Refill), the controller will direct water down through the line to the brine tank. Let the water flow through the line until all air bubbles have been purged from the line.

→ Do not let the water flow down the line to the tank for more than 1 to 2 minutes, or the tank may overflow.

→ Once the air is purged from the line, press  and  simultaneously to advance to cycle C0 (Treated Water) position.



7. Draw water from the brine tank.

→ From the treated water position (cycle C0), advance the valve to the draw brine position. Press  for 5 seconds.

The controller will begin a manual regen, and advance the control valve to the cycle C1 (Backwash). Press  and  to advance to cycle C2 (Draw).

→ With the controller in this position, check to see that the water in the brine tank is being drawn out of the tank. The water level in the tank should recede very slowly.

→ Observe the water being drawn from the brine tank for at least 3 minutes. If the water level does not recede, or goes up, check all hose connections. C2 should be displayed.

8. If the water level is receding from the brine tank you can then advance the controller back to the treated water (C0) position by pressing  and  simultaneously to advance the controller to the C0 position.
9. Finally, turn on a faucet plumbed after the water softener. Run the faucet until the water runs clear. Add salt to the brine tank.

7.1.2. Additional tips

- When the controller is first plugged in, it may display a flashing hourglass and the message "Err 3", this means that the controller is rotating to the home position. If the "Err 2" is displayed, check that the incoming power frequency matches the controller.
- The preset default time of regeneration is 2:00 AM.
- Power supply? The World controller senses the electrical input and decides which is needed.
- The 700 Series controller can be programmed to regenerate on specific days of the week.
- If electrical power is not available, the camshaft can be rotated counter-clockwise by hand if the motor is removed.
- The 700 Series controllers send commands to the motor for camshaft movement. However, water pressure/flow are required during the regeneration cycle for backwash, purge and refill, and brine draw to actually take place.
- Make sure the control power source is plugged in. The transformer should be connected to a non-switched power source.
- You can start programming from the beginning by resetting the amount of media, see chapter 6.4.7. Resetting the controller, page 57.

7.2. Sanitization

7.2.1. Disinfection of water softeners

The construction materials of the modern water softener will not support bacterial growth, nor will these materials contaminate a water supply. During normal use, a softener may become fouled with organic matter, or in some cases with bacteria from the water supply. This may result in an off-taste or odour in the water.

Some softeners may need to be disinfected after installation and some softeners will require periodic disinfection during their normal lifetime.

Depending on the conditions of use, the softener type, the type of ion exchanger, and the disinfectant available, a choice can be made among the following methods.

7.2.2. Sodium or calcium hypochlorite

These materials are satisfactory for use with polystyrene resins, synthetic gel zeolite, greensand and bentonites.

5.25% Sodium hypochlorite

If stronger solutions are used, such as those sold for commercial laundries, adjust the dosage accordingly.

Dosage

Polystyrene resin: set 1.25 mL fluid per 1 L of resin.

Non-resinous exchangers: set 0.85 mL fluid per 1 L.

Brine tank softeners

Backwash the softener and add the required amount of hypochlorite solution to the well of the brine tank. The brine tank should have water in it to permit the solution to be carried into the softener.

Proceed with the normal regeneration.

Calcium hypochlorite

Calcium hypochlorite, 70% available chlorine, is available in several forms including tablets and granules. These solid materials may be used directly without dissolving before use.

Dosage

Measure two grains ~ 0.11 mL 1 L.

Brine tank softeners

Backwash the softener and add the required amount of hypochlorite to the well of the brine tank. The brine tank should have water in it to permit the chlorine solution from being carried into the softener.

Proceed with the normal regeneration.

7.2.3. Electro chlorination

Valves or systems already equipped with an electrochlorinator device or system are supposed to be sanitized during the brine draw phase.

8. Operation

During a regeneration:

- A "C#" is displayed to show the current cycle.
- Total regeneration time remaining is displayed on screen.
- You can press and hold  to show current cycle time remaining.



Note

The current cycle is shown in a window on the back side of the controller.

8.1. Recommendations

- Use only regeneration salts designed for water softening EN973.
- For optimal system operation, the use of clean salt and impurities free is recommended (for example salt pellets).
- Do not use ice melt salt, block, or rock salts.
- The sanitizing process (both with liquid and electrochlorination) may introduce chlorine compounds which may reduce the lifetime of the ion exchange resins. Refer to media manufacturer specifications sheet for more information.

8.2. Manual regeneration



Mandatory

The controller must be in service in order to enable this procedure.



Note

The unit returns to normal operation if no buttons are pressed within 30 seconds.

Manual delayed regeneration

- A** Press  once for delayed regeneration.
- The regeneration will start on the scheduled time. See chapter 6.3. Basic programming, page 46.
 - A flashing regen symbol will be displayed.



Note

To cancel: press  again. The regen symbol disappears.

Immediate regeneration

- A** Press and hold  for 5 seconds to initiate immediate manual regeneration.
- A solid regeneration icon will be displayed.
 - Camshaft starts rotating to cycle C1.





Double regeneration

- A** After an immediate regeneration has begun, press  again to plan a second manual regeneration.
 → A flashing "x2" symbol indicates the second regeneration will start at the programmed delayed regeneration time.



Immediate double regeneration

- A** Press and hold  to start the second regeneration immediately following the current regeneration.
 → A solid "x2" symbol will be displayed.

8.3. To advance regeneration cycles

- A** Simultaneously press  and  to advance to the next cycle.
 → An hourglass will display while the camshaft is moving.
 → When the camshaft reaches next cycle, "C2" will be displayed.
- B** Repeat  and  to advance through each cycle.

8.4. To cancel a regeneration

- A** Press and hold  and  for 5 seconds to cancel the regen.
 → Hourglass will flash once cancelled.
 → Camshaft will move to service position – may take 1 to 2 minutes.

9. Maintenance



Mandatory

Cleaning and maintenance shall take place at regular intervals in order to guarantee the proper functioning of the complete system, and be documented in the Maintenance chapter in the User Guide document.



Mandatory

This valve must always be mounted with a DLFC.

9.1. Recommendations

9.1.1. Use original spare parts



Caution

To ensure correct operation and safety of the device, only use original spare parts and accessories recommended by the manufacturer.

Parts to keep in stock for potential replacements are motor and optical sensor, controller, transformer, injectors, flapper kit, O-ring kit, refill and DLFC.

9.1.2. Use original approved lubricants

- Production:
p/n 1014082 (NFO "Chemplex" 862 Silicone Comp.).
- Spare part:
p/n 42561 (SILICONE LUBRICANT PACK).

9.1.3. Maintenance instructions

- Disinfect and clean the system at least once a year or if the treated water has an off-taste or an unusual odor.
- Perform a hardness test every year for softeners.

9.2. Cleaning and maintenance

9.2.1. Cleaning and maintenance

Before any cleaning or maintenance procedure, complete the following step :

No.	Operation
	Caution These operations need to be performed before any cleaning or maintenance procedure.
A	Unplug the wall-mounted transformer.
B	Shut off water supply or put bypass valve(s) into bypass position.
C	Relieve system pressure before performing any operations.

9.2.2. Cleaning the injector valve

No.	Operation
A	Using a pliers if needed, unscrew and remove the injector cap (1).
 Caution	Take care not to damage the injector (3).
B	Check for O-rings integrity.
C	Clean the screen injector (2) and injector (3) using compressed air, a soft brush or possibly a pin.
D	Reverse above procedure steps to rebuild.

9.2.3. Cleaning the refill controller

No.	Operation
A	Using a pliers if needed, unscrew and remove the refill controller (4).
B	Clean the refill controller (4) with a soft brush. Make sure the refill controller groove is perfectly clean.
C	Check for O-rings integrity.
D	Clean the refill controller chamber (5) before reinserting the refill controller (4).
E	Reverse above procedure steps to rebuild.

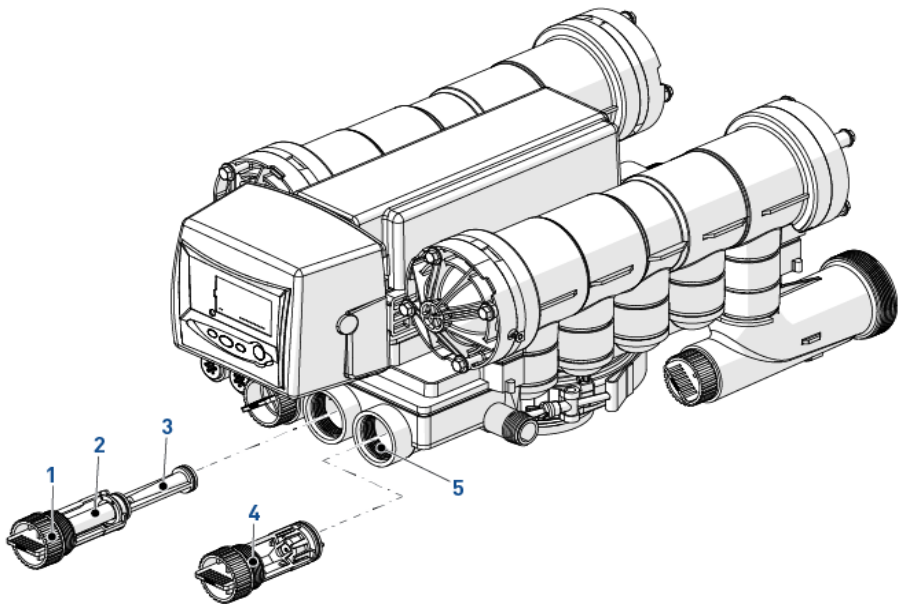

9.2.4. Cleaning the pilot filter screen

No.	Operation
A	Using a Torx key, unscrew and extract the injector screen cap (1).
B	Unclip the white plastic basket (2) and clean it with a soft brush. Use of descaling agent such as white vinegar might be required in case of impurities on the plastic basket (2).
C	Check for O-rings integrity before reinserting the injector screen cap (1).
D	Reverse above procedure steps to rebuild.

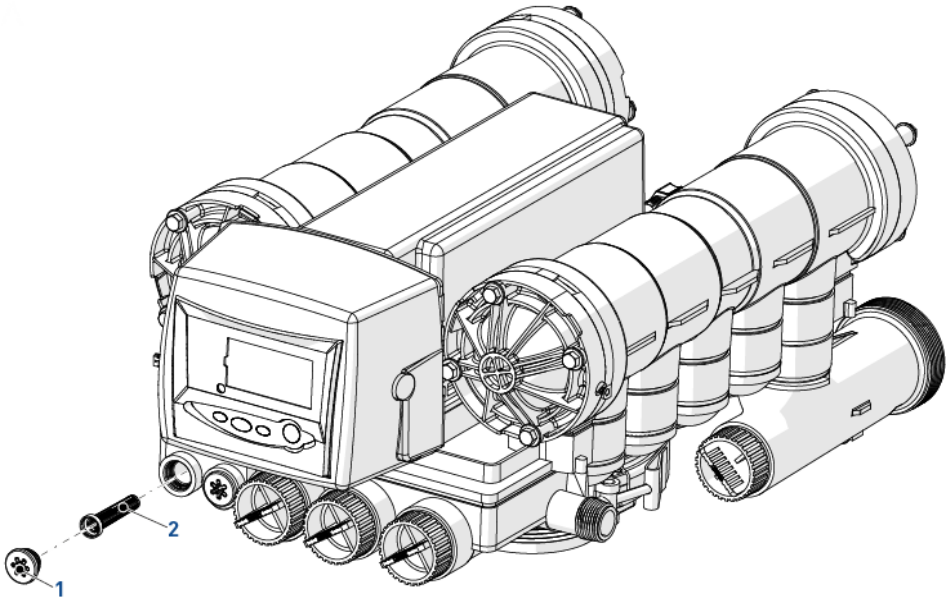

9.2.5. Disassembling controller cover

No.	Operation
A	Unlock the controller cover (1) from the slide clips (4) (one on each side of the valve).
B	Pull straight off the controller cover (1).
C	Reverse above procedure steps to rebuild.

9.2.6. Disassembling camshaft cover

No.	Operation
A	Unlock the camshaft cover (2) from the slide clips (3) (one on each side of the valve).
B	Pull off the camshaft cover (2).
C	Reverse above procedure steps to rebuild.

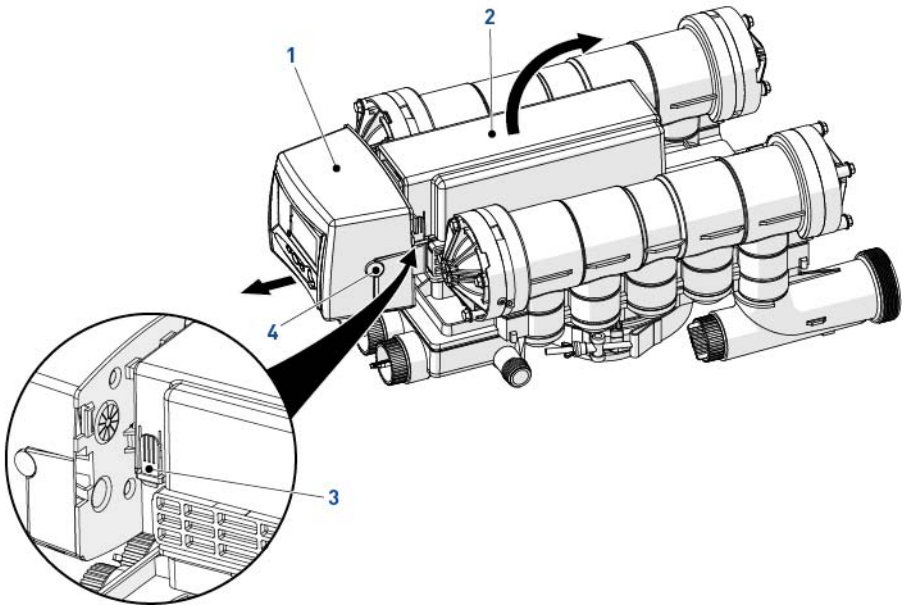

9.2.7. Motor replacement

No.	Operation
A	Remove the controller cover (1). See 9.2.5. Disassembling controller cover, page 67.
B	Press the controller locking pad (4) and slide the controller (2) out of its position.
C	Loosen the two screws (6).
D	Remove the motor (5).
E	Disconnect the motor cable (3) from the controller (2).
i	Note To replace the motor, you also have to disassemble the optical sensor. See 9.2.9. Optical sensor and controller replacement, page 70.
F	Reverse above procedure steps to rebuild.

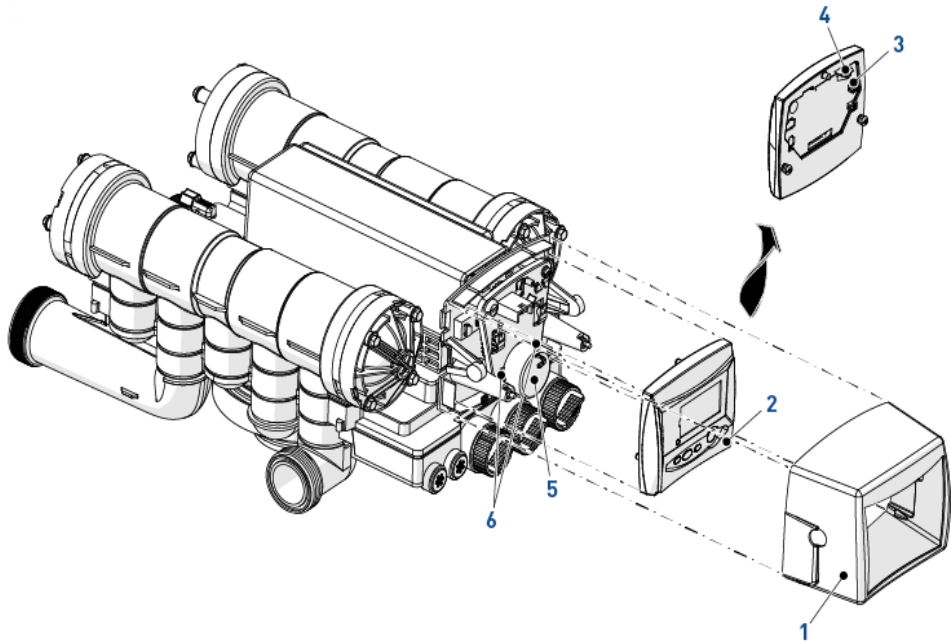

9.2.8. Camshaft replacement

No.	Operation
A	Remove the camshaft cover (1). See 9.2.6. Disassembling camshaft cover, page 67.
B	Press on the release tab (9) and pull on the back end of the camshaft (2). The front end of the camshaft will be flush with the mounting plate (6).
C	Loosen the four screws (3 and 5).
D	Remove the two pillow blocks (7 and 8).
E	Remove the camshaft (4).
F	Reverse above procedure steps to rebuild.



Note

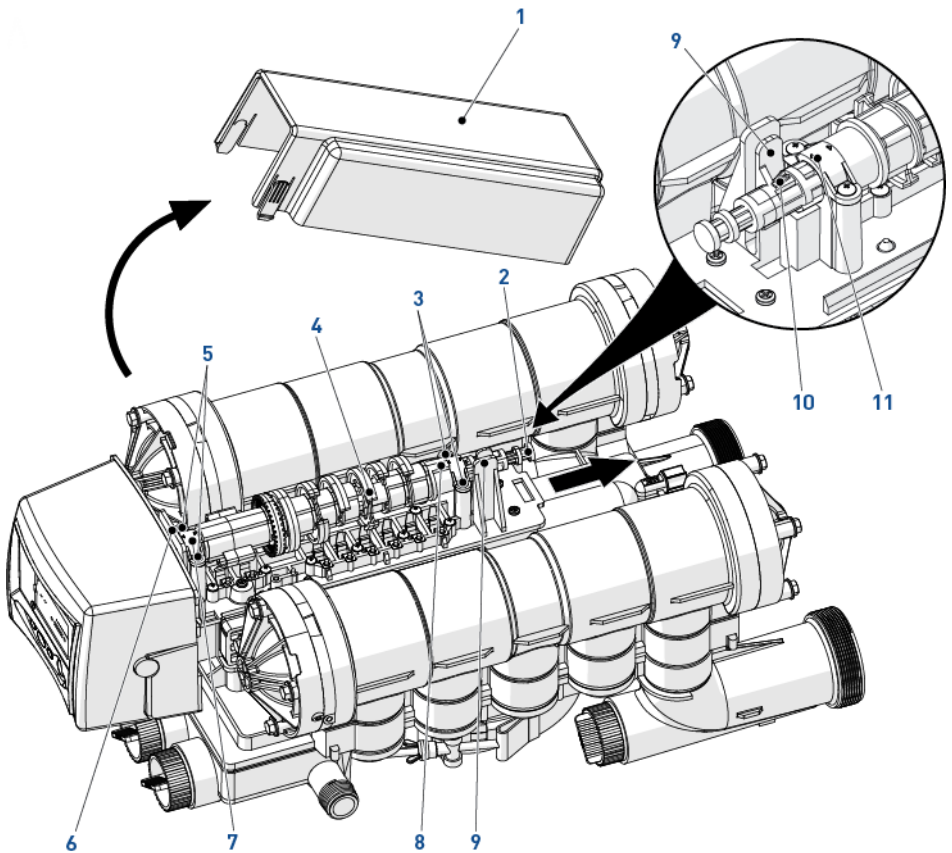

When reassembling the camshaft (4), place it through the mounting plate (6). Rotate the cam assembly counter-clockwise until the camshaft arrow (10) aligns with pillow block arrow (11). Then engage the camshaft with the controller.



9.2.9. Optical sensor and controller replacement

No.	Operation
A	Remove the controller cover (1). See 9.2.5. Disassembling controller cover, page 67.
B	Press the controller locking pad (3) and slide the controller (2) out of its position.
C	Loosen the four screws (4).
D	Remove the plate (7) and the wheel (6).
E	The optical sensor (5) is clipped on the front edge, gently press on the clips to release the optical sensor from its location.
F	Disconnect the cables from the controller by pressing on the clip and pulling them.
Note	
	To replace the optical sensor, you also have to disassemble the motor. See 9.2.7. Motor replacement, page 68.
G	Reverse above procedure steps to rebuild.
Caution	
	When refitting, always use the cables guide to secure the cables. This will prevent the cables from being crushed or cut when closing the cover.

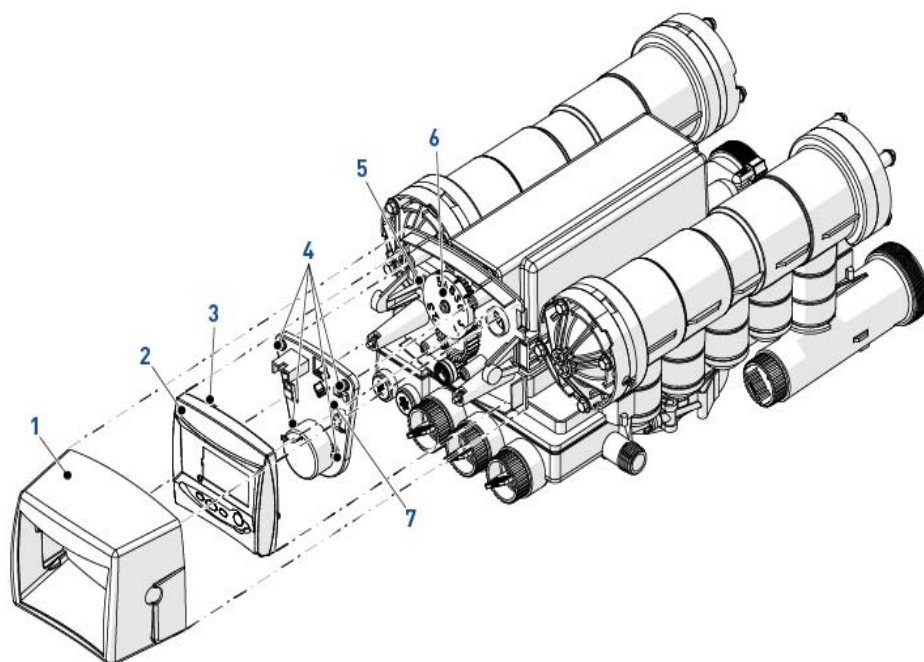

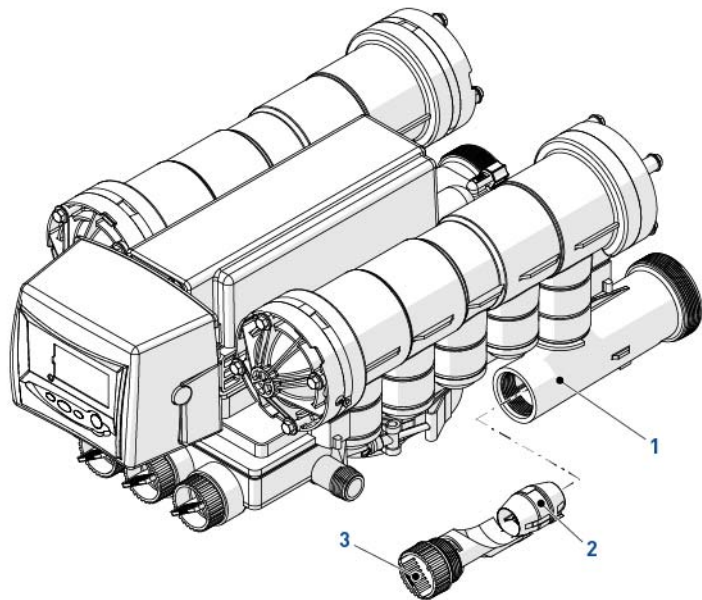

9.2.10. Turbine cleaning or replacement

No.	Operation
 Note Depending on the valve installation, the turbine may not be present in the valve. (Magnum IT : internal turbine / Magnum Cv : external turbine).	
A	Using a pliers if needed, unscrew and remove the turbine (3) from the outlet pipe (1) of the valve.
B	Clean the turbine (2) using a soft cloth and a brush.
C	Reverse above procedure steps to rebuild.



9.2.11. Top plate and disc valve replacement

No.	Operation
A	Remove the camshaft cover. See 9.2.6. Disassembling camshaft cover, page 67.
B	Remove the camshaft. See 9.2.8. Camshaft replacement, page 69.
Caution  Take care with sharp edges. Use of protective glove is highly recommended to release or remove the springs (1).	
A	Using a flat screwdriver, release the flapper springs (1) one by one (8x).
B	Loosen all top plate screws (3) (14x).
C	Remove the top plate (2) from the valve.
D	Clean or replace the flappers (4) if needed.
Note  The outline of the flapper seat can be seen on the flapper side. If the outline is irregular, this may indicate that debris is or has been preventing the flapper (4) from closing, and potential damage.	
Note  When refitting the top plate (2), always follow the screwing order below.	

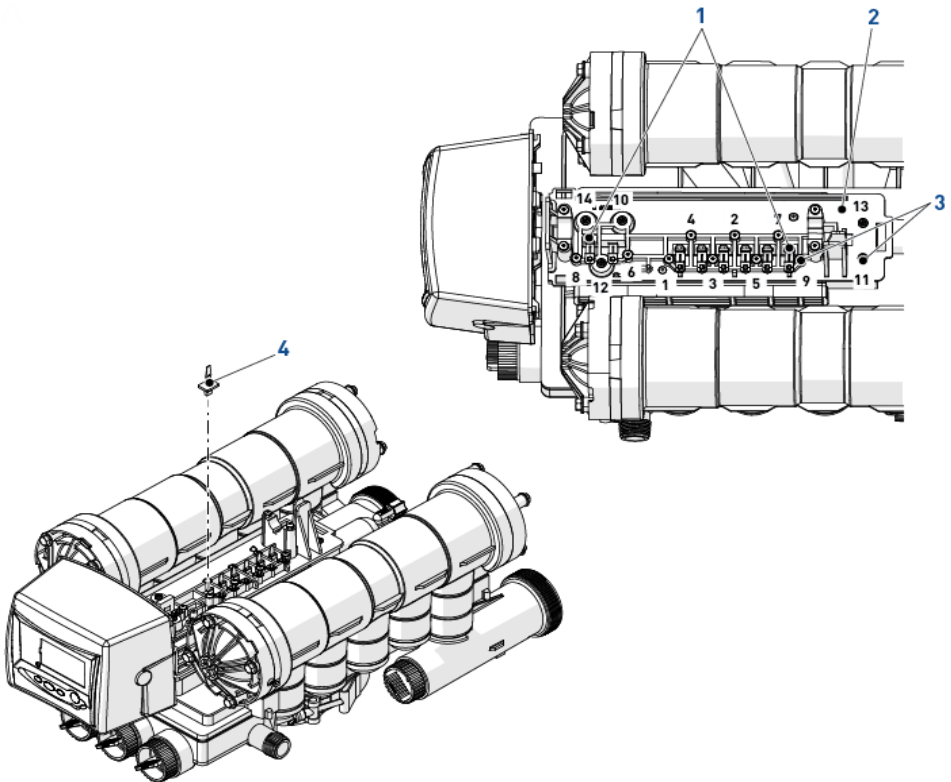

9.2.12. Cartridge replacement

No.	Operation
i	Note Removal of cartridges should be done only after reviewing all other possible causes of problem (see 10.3. Magnum valve cartridge, page 77).
i	Note There may be some difficulties to remove cartridges in valves that have been in service for a long period of time. Scale or iron build up around the O-ring seals may cause breakage in the cage assembly of the cartridge.
i	Note The controller must be removed first before removing #1 drain cartridge or #2 rinse cartridge.
A	Using a combination wrench, remove the four bolts (1).
B	Using a flat screwdriver, pry a small opening between the valve body and the second part of the cartridge.
!	Caution There are two parts or sections in the cap of the cartridge assembly. The first part is a cover for the diaphragm. The second part is attached to the main cartridge assembly. Insert the screwdriver between the valve body and the second part of the cartridge assembly (2).
C	Insert two larger flat screwdrivers at the 10 o'clock and 2 o'clock positions of the cartridge. These should be inserted approximately 1 cm into the opening created by the small screwdriver. Use then the two screwdrivers to slowly move the cartridge (4) out of the valve body.
D	Inspect, clean and / or replace the damaged part of the valve cartridge.
E	Reverse above procedure steps to rebuild.
i	Note Check that the nipples O-rings (3) are in place when the cartridge is rebuild into the valve body.

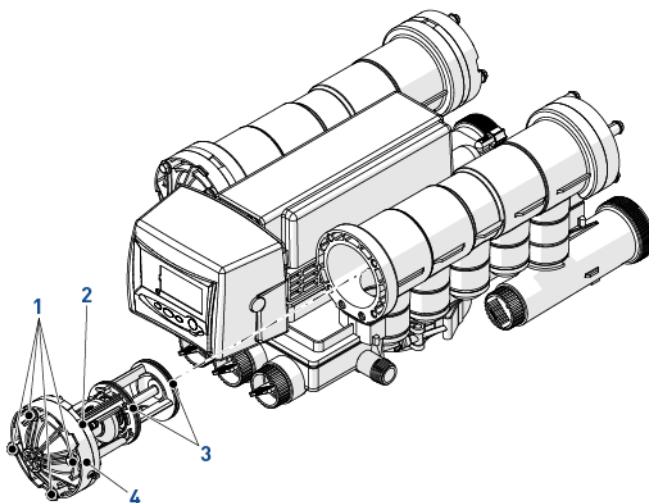

10. Troubleshooting

10.1. Logix controller

Err. code	Cause	Reset and recovery
ERR 1	Controller power has been connected and the controller is not sure of the operating status.	Reset controller. See 6.4.7. Resetting the controller, page 57.
ERR 2	Controller power does not match 50 or 60 Hz.	Disconnect and reconnect the power. If problem is not solved, obtain an appropriate controller or AC transformer.
ERR 3	Controller lost the position of camshaft. Camshaft should be rotating to find Home position.	Wait for 2 minutes: the controller returns to Home position. An hourglass icon flashes to indicate that the motor is running.
	Camshaft does not rotate.	Check: <ul style="list-style-type: none"> • Motor connections; • If motor wire harness is connected to the motor; • If motor wire harness is connected to the controller; • Optical sensor connection and position; • If motor and camshaft gears are engaged.
		If everything is connected, try replacing in this order: <ul style="list-style-type: none"> • Wire harness; • Motor; • Optical sensor; • Controller. See 9.2. Cleaning and maintenance, page 64.
Camshaft rotates for more than 5 minutes to find Home position.	Check: <ul style="list-style-type: none"> • Optical sensor connection and position; • Camshaft connection; • Camshaft slots cleanness. 	

Err. code	Cause	Reset and recovery
ERR3	Camshaft rotates for more than 5 minutes to find Home position.	If motor keeps rotating indefinitely, replace the following components in this order: <ul style="list-style-type: none"> • Wire harness; • Motor; • Optical sensor; • Controller. See 9.2. Cleaning and maintenance, page 64.
-- : --	Power failure occurred.	Press  to reset the time.

10.2. Magnum IT and Cv valve

Issue	Cause	Reset and recovery
Water softener fails to regenerate (no soft water).	Power supply to the Magnum controller has been interrupted.	<ul style="list-style-type: none"> • Determine the reason for power interruption and correct it; • Reset the time of day.
	Water pressure lost.	<ul style="list-style-type: none"> • Restore water pressure.
	Logix controller improperly programmed.	<ul style="list-style-type: none"> • Verify that the Logix controller is properly programmed.
	Defective controller.	<ul style="list-style-type: none"> • Replace the controller assembly. See 9.2.5. Disassembling controller cover, page 67.
	No salt in the brine tank.	<ul style="list-style-type: none"> • Add salt and regenerate in the tank.
	Manual bypass valve is open.	<ul style="list-style-type: none"> • Close the manual bypass valve.
	For 762 series controller, turbine meter is clogged or restricted.	<ul style="list-style-type: none"> • Inspect turbine meter assembly, clean or replace it. See 9.2.10. Turbine cleaning or replacement, page 71.
	Leak at riser pipe seal.	<ul style="list-style-type: none"> • Ensure that riser pipe is properly sealed at the tank adapter O-ring; • Inspect pipe for cracks.
	Insufficient brine.	<ul style="list-style-type: none"> • Check refill controller and clean if necessary; • Check controller settings; • Check flow rate capacities of safety float and air check assembly.
Plugged injector and / or injector screen.	<ul style="list-style-type: none"> • Inspect and clean injector and / or injector screen. 	

Issue	Cause	Reset and recovery
No brine draw.	Plugged injector and / or injector screen.	<ul style="list-style-type: none"> Inspect and clean the injector and / or injector screen assembly.
	Insufficient water pressure.	<ul style="list-style-type: none"> Increase water pressure above 172 kPa minimum.
	Obstructed drain line.	<ul style="list-style-type: none"> Remove the obstruction.
	Brine line pulling air.	<ul style="list-style-type: none"> Ensure all brine line fittings are tight.
Insufficient brine draw.	Partially clogged injector and / or injector screen.	<ul style="list-style-type: none"> Inspect and clean the injector and / or injector screen assembly.
	Restricted flow rate in brine line.	<ul style="list-style-type: none"> Check flow rate capabilities of the safety float / air check assembly.
	Insufficient water pressure.	<ul style="list-style-type: none"> Increase water pressure above 172 kPa minimum.
	Excessive back pressure on injector due to elevated drain line.	<ul style="list-style-type: none"> Reduce drain line elevation to height of valve.
	Partially restricted drain line.	<ul style="list-style-type: none"> Remove the restriction.
Insufficient refill to brine tank.	Restricted flow rate in brine line.	<ul style="list-style-type: none"> Check flow rate capabilities of the safety float / air check assembly.
	Resin volume incorrectly set.	<ul style="list-style-type: none"> Program again the controller.
Excessive water in brine tank.	Plugged drain line flow control.	<ul style="list-style-type: none"> Clean the drain line flow control.
	Plugged injector and / or injector screen.	<ul style="list-style-type: none"> Inspect and clean the injector and / or injector screen assembly.
	Incorrect refill controller.	<ul style="list-style-type: none"> Install the correct controller.
	Insufficient water pressure.	<ul style="list-style-type: none"> Ensure that operating pressure is above 172.4 kPa.
Leak to main drain.	No flow control installed in drain line.	<ul style="list-style-type: none"> Install drain line flow control.
	Insufficient water pressure.	<ul style="list-style-type: none"> Increase water pressure above 172 kPa minimum.
	Plugged injector and / or injector screen.	<ul style="list-style-type: none"> Inspect and clean the injector and / or injector screen assembly.
	Back pressure on pilot drain port.	<ul style="list-style-type: none"> Plumb pilot drain line to atmospheric position (i.e brine tank).
Loss of media to drain.	No flow control installed in drain line.	<ul style="list-style-type: none"> Install drain line flow control.
	Air or gasses in raw water.	<ul style="list-style-type: none"> Ensure that air or gasses are not present in feed water.
	Unit draws air through brine line.	<ul style="list-style-type: none"> Ensure that all brine line fittings are tight and that the aircheck closes.
	Defective air check.	<ul style="list-style-type: none"> Clean or replace aircheck.

Issue	Cause	Reset and recovery
Loss of water pressure.	Fouled resin bed due to iron accumulation.	<ul style="list-style-type: none"> Clean Magnum control valve and mineral bed with cleaner.
	Slots in riser pipe or laterals are filled with resin fines.	<ul style="list-style-type: none"> Inspect and clean distributor pipe slots as needed.
Salt in water to service after regeneration.	The injector is too small for the system size.	<ul style="list-style-type: none"> Install the correct injector.
	Brine draw time excessively long due to low water pressure.	<ul style="list-style-type: none"> Increase water pressure above 172 kPa minimum.
	Restricted drain line.	<ul style="list-style-type: none"> Remove drain line restriction.
	Insufficient rinse volume.	<ul style="list-style-type: none"> Increase slow rinse time, fast rinse time or both.
	Plugged injector and / or injector screen.	<ul style="list-style-type: none"> Inspect and clean the injector and / or injector screen assembly.

10.3. Magnum valve cartridge

The following procedure provides sequential troubleshooting steps to isolate a suspect cartridge.



Note

The dynamic pressure applied to the valve must be greater than 172.4 kPa at all times when performing the following tests. If a cartridge needs to be removed, follow the removal procedure in section 9.2.12. Cartridge replacement, page 73.

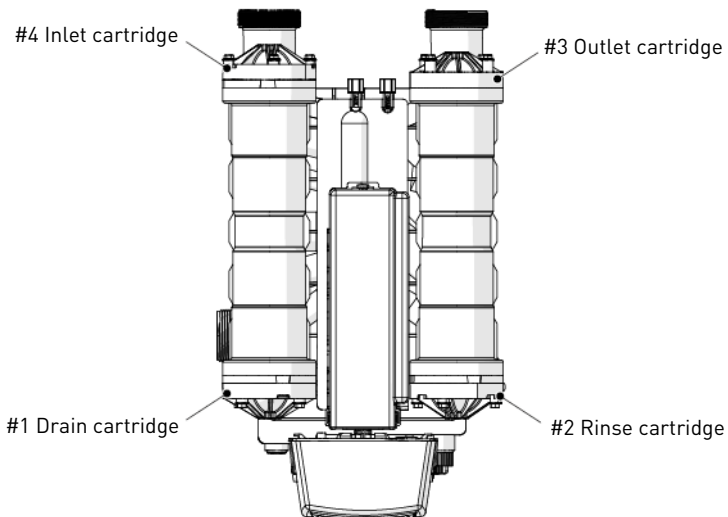

There are four symptoms that may require a cartridge to be removed and inspected or replaced.

1. A constant leak from the pilot drain in any cycle position.
 - A small discharge of water from the pilot drain while transitioning from one cycle to the next is normal. A leak from the pilot drain could be caused by the following:
 - Diaphragm failure in one of the valve cartridges. See table below for faulty cartridges.
 - Debris may prevent the flappers from closing.
 - Inspect discs and seats. Quick cycle the logix Magnum to each cycle indicated below. If the leak stops in a particular cycle, remove the cartridge listed in the right column. Inspect for wear or damage.

No leak during	Cartridge
Service cycle (C0)	#3 Outlet
Backwash (C1)	#1 Drain
Brine (C2) / Slow rinse (C3)	#2 Rinse
Fast rinse (C5)	#2 Rinse or #4 Inlet

2. A leak to the main 1.5" drain valve port.
 - If the system is newly installed, ensure that the start-up procedure has been properly followed. Refer to chapter 7. Commissioning, page 58.
 - If the system has been operating correctly for a period of time and is now leaking, regenerate the unit if the media bed is exhausted. Then proceed as follow.
 - Test the water leaking from the 1.5" drain port of the Magnum valve:
 - If it is treated, remove and inspect the #2 Rinse cartridge.
 - If it is untreated, remove and inspect the #1 Drain cartridge.
3. Leakage of untreated water to service.
 - Leak at riser pipe seal or any other cause mentioned in this troubleshooting chapter.
 - Bypassing of untreated water by #4 Inlet cartridge. Remove and inspect it.
4. Leak between the main valve body and the cartridge assembly.
 - Remove and replace the two small O-rings at 5:30 and 6:30 positions of the cartridge (part number for the O-ring set : P/N 1010116. See chapter 11.7. Magnum cartridges, page 86).



Note

Replacement cartridges are only available as complete assemblies.

Cartridge #1	Drain	P/N 1000366
Cartridge #2	Fast rinse	P/N 1000365
Cartridge #3	Service	P/N 1000366 (No bypass)
		P/N 1000336 (Cap only for bypass)
Cartridge #4	Inlet	P/N 1000317

11. Spare parts

11.1. Magnum Logix valve body

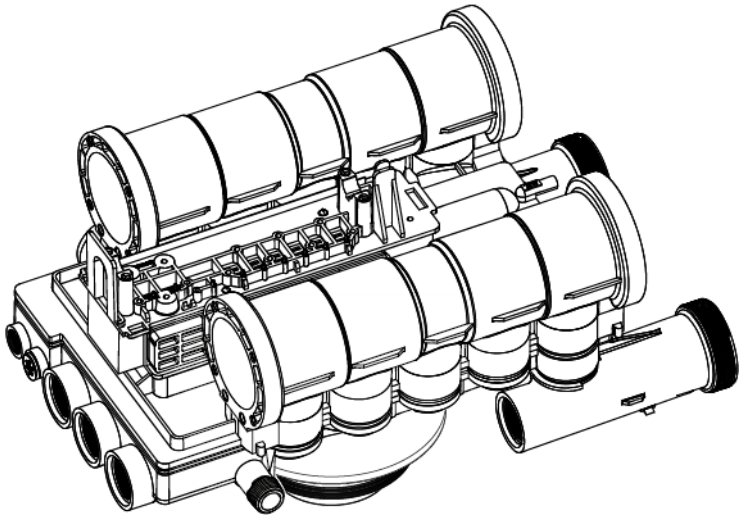

Item	Part number	Description	Packaging quantity
-	3007801	Magnum Cv valve body cartridges, HWB / UWB, Magnum Logix single camshaft	1
-	3007803	Magnum Cv valve body cartridges, NHB / NUB, Magnum Logix single camshaft	1
-	3007805	Magnum IT valve body cartridges, HWB / UWB, Magnum Logix camshaft	1
-	3007806	Magnum IT valve body cartridges, NHB / NUB, Magnum Logix camshaft	1

11.2. Magnum connections

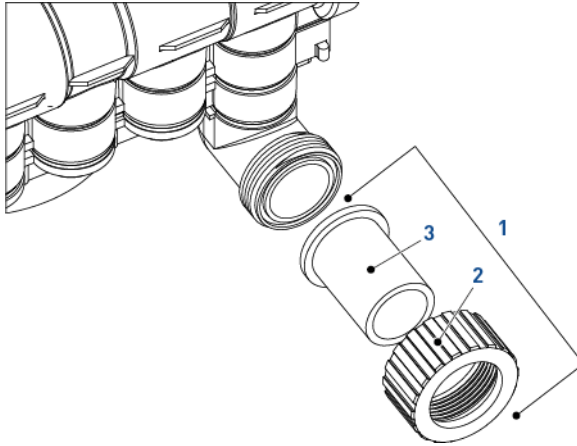

Item	Part number	Description	Packaging quantity
1	1001655	Magnum Cv 1 1/2" - 1 1/2" PVC adapter kit	1
-	1001656	Magnum Cv 1 1/2" - 50 mm PVC adapter kit	1
-	3023674	Magnum IT / Cv plus 2" - 2" BSP adapter kit	1
-	1040784	Magnum IT / Cv plus 2" - 2" PVC adapter kit	1
-	1040785	Magnum IT / Cv plus 2" - 63 mm PVC adapter kit	1
2	1000356	1 1/2" adapter nut for Magnum Cv	1
3	3014556	1 1/2" stainless steel BSP adapter	1
-	1000358	1 1/2" PVC adapter	1
-	1000359	50 mm metric CPVC adapter	1
-	1010160	1 1/2" adapter O-ring	1
-	1010165	2" adapter O-ring	1
-	1040921	Side mount adapter	1
-	1010162	O-ring tank adaptor	1
-	1010160	Riser tube O-ring	1
-	3024790	Magnum stainless steel tank adaptor 4"	1
-	CH20805	Magnum tank adaptor, Noryl 6" flanged kit	1

11.3. Magnum Logix camshaft and pilot

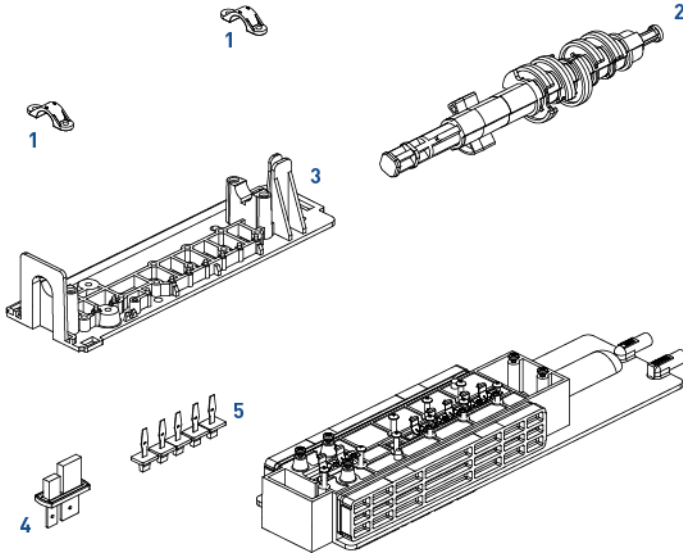

Item	Part number	Description	Packaging quantity
1	1000589	Pillow block cap	2
2	1267726	Camshaft logix Magnum single tank	1
-	1000341	Shaft, cam, Magnum	1
3	1000339	Top plate	1
-	3018941	Pillow block and top plate screw (long)	19
4	1000391	Brine flapper valve	1
5	1000328	Pilot flapper valve	6
-	1001580	Valve flapper spring	14
-	1040692	Kit flapper (includes items 4, 5 and springs)	1
-	1000343	Cam cover	1
-	1000553	Cam pilot auxiliary twin (shuts off at end of refill)	1
-	1000554	Cam pilot auxiliary single (shuts off at begin of refill)	1
-	1041064	Breakaway cam kit for auxiliary output	1
-	1000455	Brine draw cam single	1

11.4. Magnum refill controller assembly

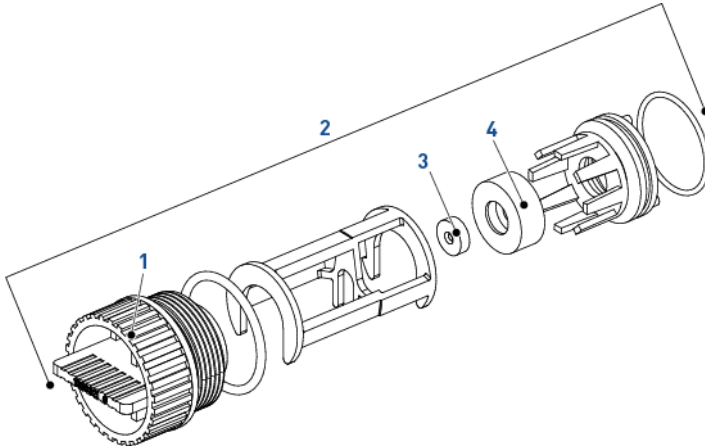

Item	Part number	Description	Packaging quantity
1	1040688	Flow controller plug	1
2	1041687	Refill controller assembly	1
3	1000421	Refill flow controller for 14" tank - 0.7 gpm [0.16 m ³ /h]	1
-	1000422	Refill flow controller for 16" tank - 0.8 gpm [0.18 m ³ /h]	1
-	1000423	Refill flow controller for 18" tank - 1.0 gpm [0.23 m ³ /h]	1
-	1000424	Refill flow controller for 21" tank - 1.4 gpm [0.32 m ³ /h]	1
-	1000425	Refill flow controller for 24" tank - 2.0 gpm [0.45 m ³ /h]	1
-	1000426	Refill flow controller for 30" tank - 3.0 gpm [0.68 m ³ /h]	1
-	1000427	Refill flow controller for 36" tank - 5.0 gpm [1.14 m ³ /h]	1
4	1000479	Refill flow controller cage	1

11.5. Magnum injector assembly

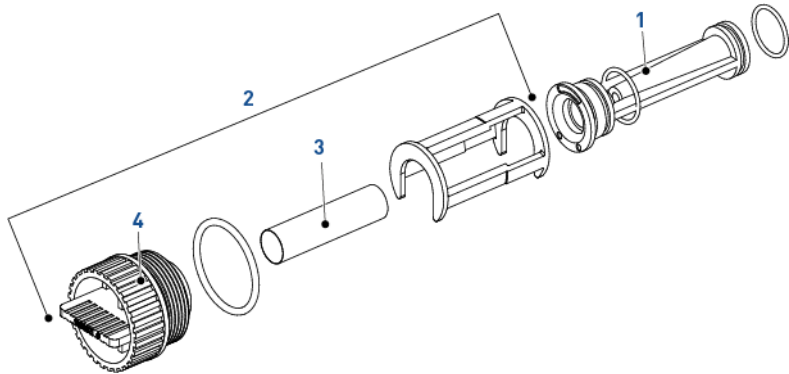

Item	Part number	Description	Packaging quantity
1	-	Injectors with O-rings	-
-	1040670	Injector for 14" tank - 0.5 gpm (0.11 m ³ /h)	1
-	1040671	Injector for 16" tank - 0.5 gpm (0.11 m ³ /h)	1
-	1040672	Injector for 18" tank - 0.6 gpm (0.14 m ³ /h)	1
-	1040673	Injector for 21" tank - 0.9 gpm (0.2 m ³ /h)	1
-	1040674	Injector for 24" tank - 1.4 gpm (0.32 m ³ /h)	1
-	1040675	Injector for 30" tank - 2.0 gpm (0.45 m ³ /h)	1
-	1040676	Injector for 36" tank - 3.3 gpm (0.75 m ³ /h)	1
-	1040669	Blank injector	1
2	1040677	Injector assembly (less injector)	1
3	1000322	Injector screen	1
4	1040688	Plug for injector, refill and pressure regulator ports (including O-rings)	1

11.6. Magnum drain line flow controls assembly

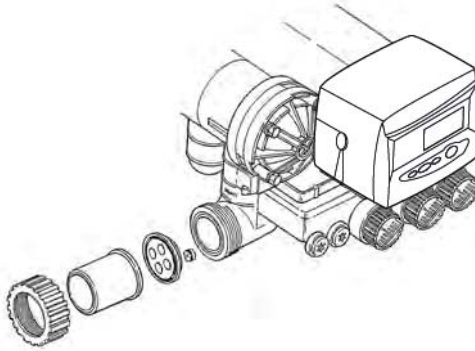

Item	Part number	Description	Packaging quantity
-	-	Assembled DLFC with out O-ring and flow controls Inserts	-
-	1040720	DLFC 5 gpm (1.14 m ³ /h) (for 14" softener) BLU-BLK-BLK-BLK	1
-	1040721	DLFC 6 gpm (1.36 m ³ /h) (for 16" softener) RED-BLK-BLK-BLK	1
-	1040722	DLFC 7 gpm (1.59 m ³ /h) BRN-BLK-BLK-BLK	1
-	1040723	DLFC 8 gpm (1.82 m ³ /h) (for 18" softener) GRN-BLK-BLK-BLK	1
-	1040724	DLFC 9 gpm (2.04 m ³ /h) WHI-BLK-BLK-BLK	1
-	1040725	DLFC 10 gpm (2.27 m ³ /h) (for 21" softener) BLU-BLU-BLK-BLK	1
-	1040726	DLFC 11 gpm (2.5 m ³ /h) RED-BLU-BLK-BLK	1
-	1040727	DLFC 12 gpm (2.73 m ³ /h) RED-RED-BLK-BLK	1
-	1040728	DLFC 13 gpm (2.95 m ³ /h) BRN-RED-BLK-BLK	1
-	1040729	DLFC 14 gpm (3.18 m ³ /h) (for 24" softener) BRN-BRN-BLK-BLK	1
-	1040740	DLFC 15 gpm (3.41 m ³ /h) BLU-BLU-BLU-BLK	1
-	1040741	DLFC 16 gpm (3.63 m ³ /h) GRN-GRN-BLK-BLK	1
-	1040742	DLFC 17 gpm (3.86 m ³ /h) WHI-GRN-BLK-BLK	1
-	1040743	DLFC 18 gpm (4.09 m ³ /h) WHI-WHI-BLK-BLK	1
-	1040744	DLFC 19 gpm (4.31 m ³ /h) WHI-ORA-BLK-BLK	1
-	1040745	DLFC 20 gpm (4.54 m ³ /h) (for 30" softener) BLU-BLU-BLU-BLU	1

Item	Part number	Description	Packaging quantity
-	1040746	DLFC 21 gpm (4.77 m ³ /h) BRN-BRN-BRN-BLK	1
-	1040747	DLFC 22 gpm (5.0 m ³ /h) GRN-GRN-RED-BLK	1
-	1040748	DLFC 23 gpm (5.22 m ³ /h) GRN-GRN-BRN-BLK	1
-	1040749	DLFC 24 gpm (5.45 m ³ /h) RED-RED-RED-RED	1
-	1040730	DLFC 25 gpm (5.68 m ³ /h) GRN-GRN-WHI-BLK	1
-	1040731	DLFC 26 gpm (5.9 m ³ /h) WHI-WHI-GRN-BLK	1
-	1040732	DLFC 27 gpm (6.13 m ³ /h) WHI-WHI-GRN-BLK	1
-	1040733	DLFC 28 gpm (6.36 m ³ /h) BRN-BRN-BRN-BRN	1
-	1040734	DLFC 29 gpm (6.59 m ³ /h) BRN-BRN-BRN-GRN	1
-	1040735	DLFC 30 gpm (6.81 m ³ /h) (for 36" softener) ORA-ORA-ORA-BLK	1
-	1040736	DLFC 31 gpm (7.04 m ³ /h) GRN-GRN-GRN-BRN	1
-	1040737	DLFC 32 gpm (7.27 m ³ /h) GRN-GRN-GRN-GRN	1
-	1040738	DLFC 33 gpm (7.49 m ³ /h) GRN-GRN-GRN-WHI	1
-	1040739	DLFC 34 gpm (7.72 m ³ /h) GRN-GRN-GRN-ORA	1
-	1040750	DLFC 35 gpm (7.95 m ³ /h) WHI-GRN-GRN-GRN	1
-	1040751	DLFC 36 gpm (8.18 m ³ /h) WHI-WHI-WHI-WHI	1
-	1040752	DLFC 37 gpm (8.4 m ³ /h) WHI-WHI-WHI-ORA	1
-	1040753	DLFC 38 gpm (8.63 m ³ /h) ORA-ORA-ORA-GRN	1
-	1040754	DLFC 39 gpm (8.86 m ³ /h) ORA-ORA-ORA-WHI	1
-	1040755	DLFC 40 gpm (9.08 m ³ /h) ORA-ORA-ORA-ORA	1
-	1040762	DLFC disc with out flow controls inserts	12
-	1040763	Flow controls inserts, BLK, 0 gpm (0 m ³ /h)	25
-	1040756	Flow controls inserts, BLU, 5 gpm (1.14 m ³ /h)	25
-	1040757	Flow controls inserts, RED, 6 gpm (1.36 m ³ /h)	25
-	1040758	Flow controls inserts, BRN, 7 gpm (1.59 m ³ /h)	25
-	1040759	Flow controls inserts, GRN, 8 gpm (1.82 m ³ /h)	25
-	1040760	Flow controls inserts, WHI, 9 gpm (2.04 m ³ /h)	25
-	1040761	Flow controls inserts, ORA, 10 gpm (2.27 m ³ /h)	25
-	1010160	O-ring, DLFC	1

11.7. Magnum cartridges

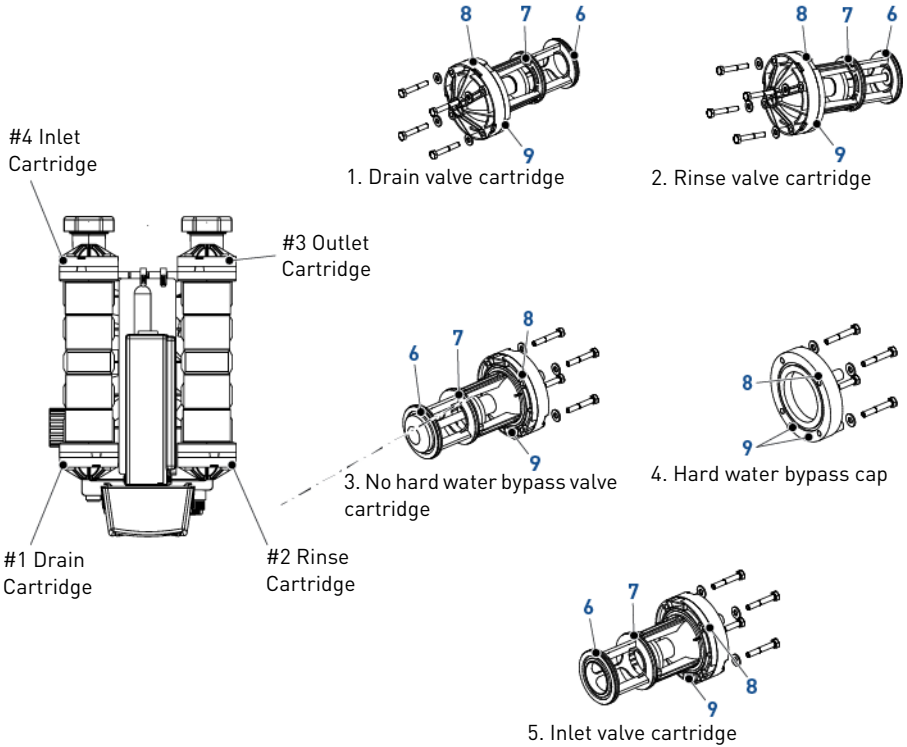

Item	Part number	Description	Packaging quantity
1	1000366	Drain valve / no hard water bypass valve cartridge	1
2	1000365	Rinse valve cartridge	1
3	1000366	Drain valve / no hard water bypass valve cartridge	1
4	1000336	Hard water bypass cap	1
5	1000317	Inlet valve cartridge	1
6	1010157	O-ring	1
7	1010158	O-ring	1
8	1231646	O-ring	1
9	1010116	O-ring	2
-	1040690	O-ring kit (includes 1x #8 and 2x #9)	1
-	1040689	O-ring kit (includes 1x #6, 1x #7, 1x #8 and 2x #9)	1

11.8. Magnum Logix controllers

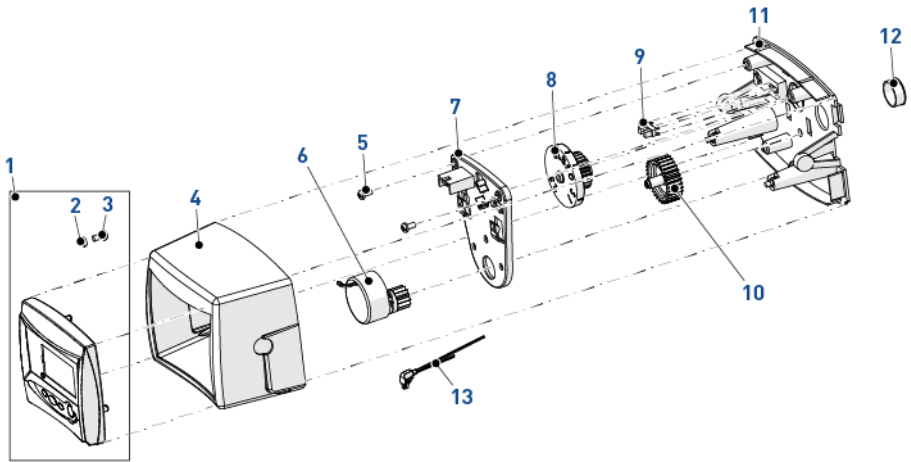

Item	Part number	Description	Packaging quantity
1	1265832	Timer Logix 742F Magnum	1
-	1265833	Timer Logix 762F Magnum	1
-	1265834	Timer Logix 742 Magnum	1
-	1265835	Timer Logix 762 Magnum	1
2	1266224	Bushing, Logix mount	2
3	1005981	Screw	2
4	1262674	Cover, Logix Magnum	1
5	1005981	Screw	2
6	1238861	Motor spacer, pinion & cable, 700 series controller 12V 50 / 50 Hz	1
7	1262673	Gear plate, Magnum Logix controller	1
8	1262581	Drive gear, Magnum Logix controller	1
9	1235373	Module, sensor, photo interrupter	1
10	1262672	Idle gear, Magnum Logix controller	1
11	1262580	Back plate, Magnum Logix controller	1
12	1239647	Bushing, cable	1
13	1266722	Turbine cable, Logix, 32" (Magnum It Logix)	1

Item	Part number	Description	Packaging quantity
-	1266723	Turbine cable, Logix, 3.05 m (Magnum Cv Logix)	1
-	1266724	Turbine cable, Logix, 7.62 m	1
5+6+7+8+9	1233809	Logix Magnum controller mechanical assembly (items #5, 6, 7, 8, 9, 10, 12)	1
-	1000813	Wall mount transformer 220 V / 12 V UK	1
-	1000814	Wall mount transformer 220 V / 12 V EUR	1
-	1001858	Wall transformer hard wired 12 V UK	1
-	1263718	Remote mount kit, with 3.05 m cable (controller not included)	1
-	1256257	Remote mount kit, no cable (controller not included)	1

11.9. Magnum IT turbine

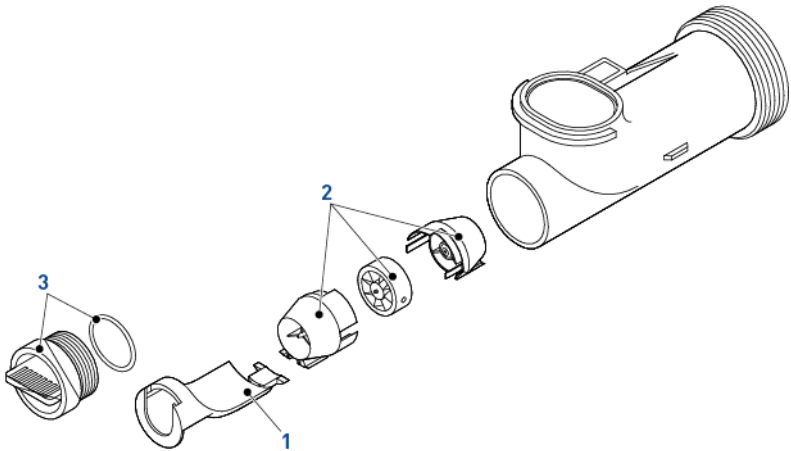

Item	Part number	Description	Packaging quantity
1	1000074	Insert, corner 2"	1
2	1232965	Assembly, turbine 2" elbow	1
3	1040688	Assembly, plug	1
-	1266722	Cable and turbine sensor, Logix Magnum IT, 32"	1

11.10. 2" external turbine assembly

Item	Part number	Description	Packaging quantity
-	1033358	2" turbine only	1
-	3023537	2" turbine assembly with 2" stainless steel BSP adapters	1
-	1034080	2" turbine assembly with 2" PVC adapters	1
-	1034081	2" turbine assembly with 63 mm PVC adapters	1
-	1030891	Gasket, 2"	2
-	1266723	Cable and turbine sensor, Logix Magnum Cv, 3.05 m	1
-	1266724	Cable and turbine sensor, Logix Magnum Cv, 7.62 m	1

11.11. 1" external turbine assembly

Item	Part number	Description	Packaging quantity
-	1033317	1" turbine only	1
-	1033238	1" turbine assembly with 1" PVC adapters	1
-	1033239	1" turbine assembly with 32 mm PVC adapters	1
-	1034385	1" adapter nut for 1" turbine and perf.	2
-	1030541	Gasket for 1" pipe or tube	2
-	1266723	Cable and turbine sensor, Logix Magnum Cv, 3.05 m	1
-	1266724	Cable and turbine sensor, Logix Magnum Cv, 7.62 m	1

11.12. Magnum miscellaneous

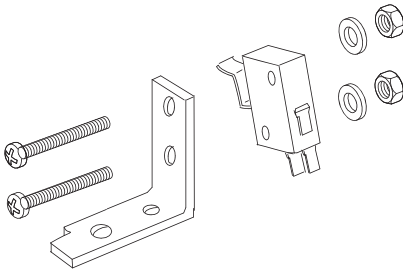

Switch kit

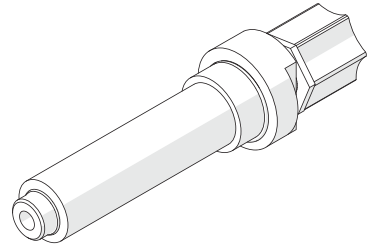

External pilot feed adapter

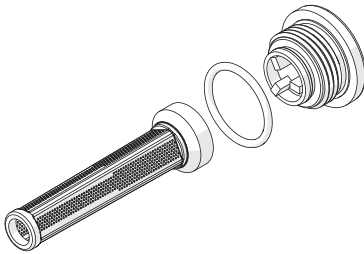

Pilot filter screen assembly

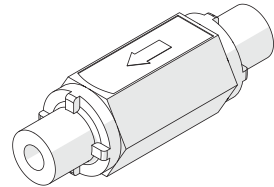

Pilot system check valves

Item	Part number	Description	Packaging quantity
1	3019468	Kit 1 switch 0.1 Amp	1
-	3019469	Kit 1 switch 5 Amp	1
-	3019467	Kit 3 switch 5 Amp	1
-	3019466	Kit 3 switch 0.1 Amp	1
-	1239979	Cable harness for remote regeneration on 74XF / switch connector	1
-	1034356	Auxiliary micro switch breakaway cam (black)	
2	1000226	Pilot screen assembly (includes pilot screen, pilot screen cap and O-ring)	1
3	1040668	External pilot feed adapter (separate source pilot water)	1
4	1009817	Pilot system check valve (to be used with #3)	1
-	3019522	Kit switch 0.1 Amp	1
-	3019523	Kit switch 0.5 Amp	1
-	3025780	Internal pilot system check valve	1

11.13. Magnum 298 installation components

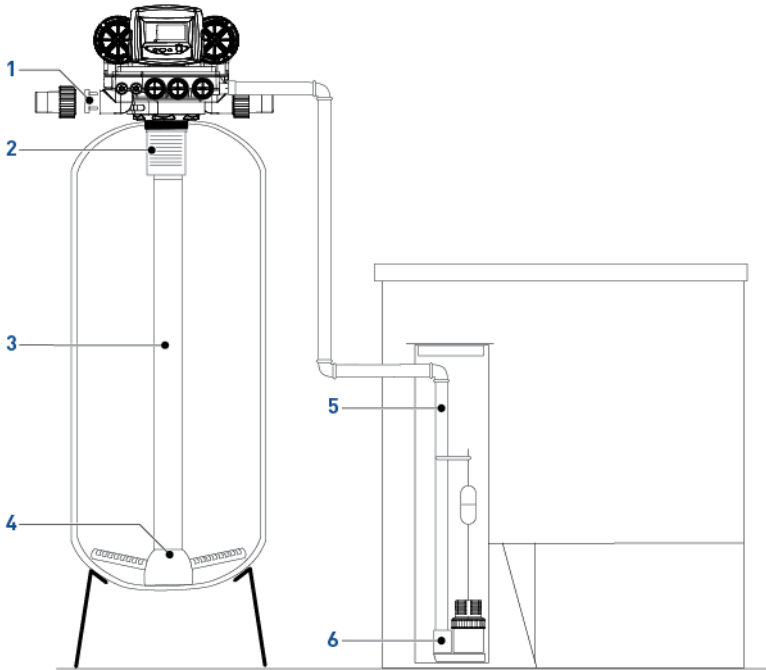

Item	Part number	Description	Packaging quantity
1	-	Drain line flow control (refer to DLFC list, see chapter 11.6. Magnum drain line flow controls assembly, page 84)	1
2	1009115	Upper screen	1
3	3028330	Riser tube	1
4	1036846	Lower distributor (for 14" and 16" Vessels)	1
-	1037112	Lower distributor (for 18", 21" and 24" Vessels)	1
-	1037120	Lower distributor (for 30" Vessels)	1
-	3028260	Lower distributor (for 36" Vessels)	1
5	A04240	Brine valve tube	1
6	A04230	Brine valve	1
-	3030638	Adapter 3/4" - 25 mm ISO PVC	1

11.14. Magnum 293 installation components

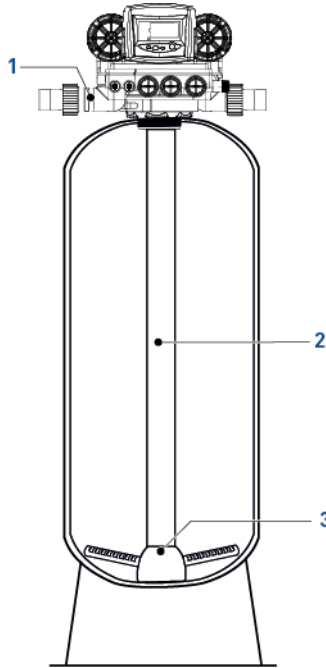

Item	Part number	Description	Packaging quantity
1	-	Drain line flow control (refer to DLFC list, see chapter 11.6. Magnum drain line flow controls assembly, page 84)	1
2	3028330	Riser tube	1
3	1036846	Lower distributor (for 14" and 16" Vessels)	1
-	1037112	Lower distributor (for 18", 21" and 24" Vessels)	1
-	1037120	Lower distributor (for 30" Vessels)	1
-	3028260	Lower distributor (for 36" Vessels)	1

12. Scrapping

The device must be scrapped in accordance with directive 2012/19/EU or the environmental standards in force in the country of installation. The components included in the system must be separated and recycled in a waste recycling center that conforms with the legislation in force in the country of installation. This will help to reduce the impact on the environment, health, safety and help to promote recycling. Pentair does not collect used product for recycling. Contact your local recycling center for more information.





www.pentairaqueaeurope.com